



Vehicle Cellular Series VH87R-061B0 EN50155 Cellular Gateway

Get Vehicles On-Line at Instant

VH87R-061B0 is a Cat-6 LTE-based gateway that brings simplicity to wireless connection process. With worldwide LTE spectrum, it enables WAN connectivity for moving vehicles and contribute a reliable bi-directional communication for other on-board electronic devices. Intelligent network monitoring allows VH87R-061B0 to re-connect automatically or fail over to alternative SIM.

Mobile WiFi Hotspot

Providing Internet and WiFi access to riders has become an essential service. VH87R-061B0 equips dual WiFi radios that can support con-current 2.4GHz and 5GHz dual-band WiFi hotspot for trains or metros. Working with external portal server enables an efficient way of user authentication and billing. QoS and bandwidth management also guarantee a better quality of use experience.

Geo Location Tracking

VH87R-061B0 has a built-in GPS receiver that can retrieve location data from global GPS satellite system, and then forward to remote servers or save in local storage. It is helpful to track locations of vehicles and integrate with LBS (Location-Based Service) or AVL (Automatic Vehicle Location) applications. With NMEA 0183 standard format, it is much easier for backend servers integration.

In-Vehicle Networking

Thanks to multiple interfaces on VH87R, it makes VH87R as a communication hub for other on-board electronic devices. Through its Gigabit Ethernet, digital IO, and serial, it's easier to connect surveillance system, passenger information system, emergency intercom, smoke detector, lavatory door/light sensors, and alarms aboard. VH87R can take first action on events based on pre-set criteria.

Dedicated to Rolling Stock

Many challenges in the way for electronic devices in trains, including unstable power source, transients, vibration, and extreme temperature. To overcome those problems, VH87R-061B0 adopts special hardware components that are compliant to EN50155 and EN50121-3 requirements. More robust M12 connectors are used to advance vibration resistance to meet IEC61373 standard.

Block Diagram

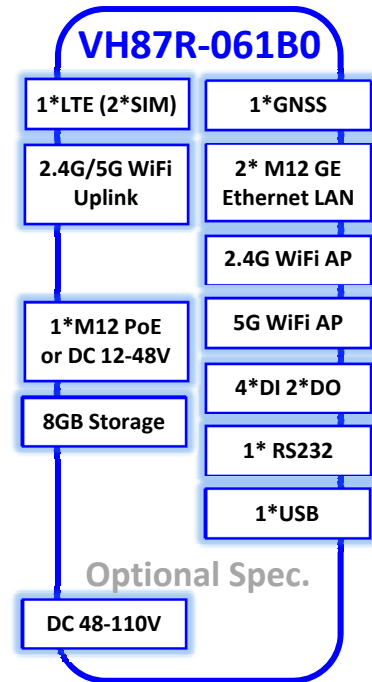

Applications & Industries

- Applications:
 - ✓ Passenger WiFi
 - ✓ Location tracking
 - ✓ Integration with on-board passenger information system, door/light control smoke/fire sensor, surveillance system
- Industries:
 - ✓ Rolling Stock

Connection Diagram

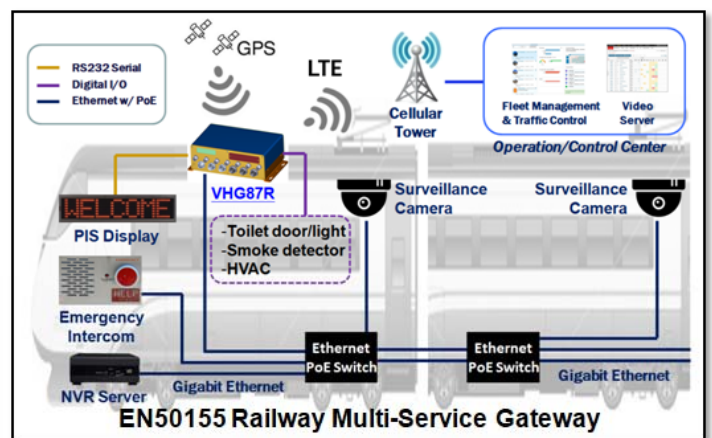
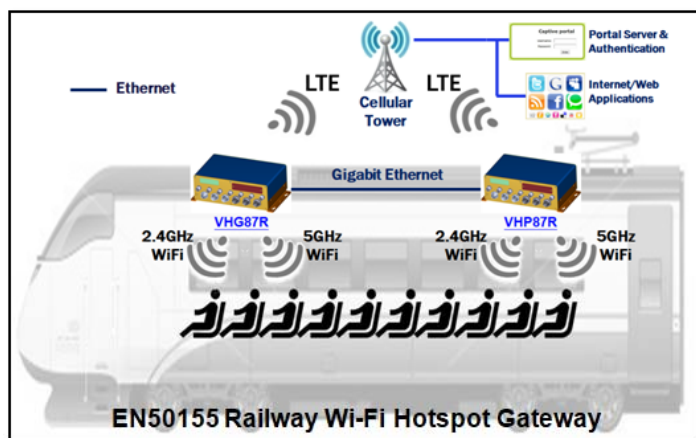

Specification Summary

Device Interface

- **LTE Module:** 1*LTE-Cat.6, 2*SIM, with GNSS (-061B0)
- **Ethernet:** 2* M12 (X-coded) GE (Eth2 is with PoE input)
- **WiFi:** 1*11n-2*2, 1*11ac-2*2 High Power
- **Field Bus:** 1* M12 (A-coded) RS232 (TX/RX)
- **Log Storage:** Embedded 8GB, 1*USB
- **I/O:** 4* DI ("Logic 0": 0~3V, "Logic 1": 10~30V)
2* DO (Sink Mode)
- **Power Input:** 1* M12 (A-coded) DC 24V, 36V according to EN50155 (12V~48V) or through PoE (Eth2) (Optional extended for 48V, 72V, 96V, 110V)

- **Antenna Con.:** 2*TNC-LTE, 4*TNC-WiFi, 1*TNC-GPS

WAN & Uplink

- **WAN:** Cellular & Config. Ether-WAN; Failover, Load Balance,
- **Cellular:** 3GPP, 2G/3G/LTE, IP Pass-through, IPv4/6
- **Ether-WAN:** Dynamic IP, Static IP, PPPoE, PPTP, L2TP
- **Wi-Fi uplink:** Auto AP scan, profile for APs link priority
- **Network Monitor:** ICMP/DNS Query

WiFi

- **Standard:** 802.11 Industry Compliance
- **Mode:** AP Router, WDS, WDS Hybrid Modes
- **Functions:** Multi-SSID, WMM
- **Security:** WEP, WPA, WPA2, WPA-PSK, WPA2-PSK, 802.1x
- **Captive Portal:** External & Internal web portal

Protocol

- **LAN & VLAN:** DHCP Server/Relay, Port/Tag based VLAN
- **IPv6:** Dual Stack, 6-in-4, 6-to-4
- **Port Forward:** NAT 1-1, 1-many, transversal, DMZ, Virtual Server & Computer, VPN Pass-through
- **Routing:** Static, Dynamic - RIP1/RIP2, OSPF, BGP
- **QoS:** Policy-based, 802.1q and TOS for priority queues

Object

- **Scheduling:** Time Schedule List
- **Grouping:** Host Grouping List
- **Ext. Server:** Email, Syslog, RADIUS, SCEP, FTP, DDNS, IGMP
- **Certificate:** My Certificate, Trusted Certificate, Issue Certificate

Service

- **Cellular Toolkit:** Data Usage, SMS, SIM PIN, USSD, Network Scan
- **Event Handling:** User Defined Manage/Notify Event; Action & Trigger by SMS, Mail, Syslog, SNMP Trap, I/O, System HW
- **GNSS:** GPS Location Tracking / Viewer

Security

- **VPN Tunneling:** IPSec, OpenVPN, PPTP, L2TP, GRE
- **Scenario:** Site/Host to Site/host; Hub and Spoke; Dynamic VPN
- **VPN Capability:** IPSec: up to 16 tunnels
- **Firewall:** SPI Firewall with Stealth Mode, IPS
- **Access Control:** Packet Filter, URL Blocking, MAC Filter
- **Authentication:** MAC based, Portal based Int./Ext LDAP/AD DB

Field Com

- **Virtual COM:** RFC2217, TCP Client, TCP Server, UDP

Administration

- **Configuration:** Web UI, CLI, Command Script, Python
- **Management:** SNMPv3 Std. & AMIT MIB, TR069
- **System:** Upgrade, Backup & Restore, Reboot & Reset, SysLog
- **FTP:** FTP Server, User Account
- **Diagnostic:** Packet Analyzer, Diagnostic Tools

Environment

- **Operation Temp.:** -40°C ~ 70°C (EN50155 TX Class)
- **Storage Temp.:** -40°C ~ 85°C
- **Humidity:** 10%~95% (non-condensing)
- **Enclosure:** Metal, Bracket
- **Dimension:** 195x125x68 mm (exclude mounting tab)

Certification

- CE
 - ✓ EMI: EN 55032: 2015 +AC: 2016 Class B
 - ✓ EMS: EN 55024, IEC 61000,
 - ✓ Radio: EN 301 489, EN 300 328, EN 301 893, EN50385
 - ✓ Safety: EN 60950-1
- Rail-related
 - ✓ EN50155
 - ✓ EN50121-3

Shock/Vibration

- IEC61373

Package Accessory

- 1* VH87R-061B0
- 1* Screw Bag
- 1* CD (User Manual)

SKU Information

VHG87R-061B0-00-yy : LTE Cat.6

'yy': Area Variant. As below table

yy	Skew	Band	Module Cert.	System Cert.	GNSS
E0	EU	B1/3/5/7/8/20/38/40/41	CE,GCF	CE	GPS
R0	Russia	B3/7/20	-	EAC	GPS
U0	US	B2/4	PTCRB, AT&T	TBC	GPS
J0	Japan	B1/9/18/19/21	TELEC, NTT, KDDI	TBC	GPS
J1	Japan	B1/8/41	TELEC, Softbank	TBC	GPS
T0	Taiwan	B3/7/8/28	NCC	TBC	GPS
C0	China	B3/39/40/41	SRRC	TBC	GPS
A0	Australia	B1/3/5/7/28/40	RCM	TBC	GPS

- Specifications are subject to change without prior notice.
- Besides CE, other regional certification needs to be checked for availability.

Mechanic Drawing

(1) Front View



(2) Back View

