

IOG851-0TL01 IOG851-06L01 4G IIoT LoRa Gateway



The IOG851 is optimized to acquire, process and filter large amount of real-time data. It creates secure IIoT system and enables cloud integration providing full operational control over field devices from any place in the world. The cost-effective industrial network solution is easy to scale connecting wide range of assets as systems, logic controllers, actuators, and sensors.

Applications:

- Industrial IoT and networking
- System cloud integration
- Smart City and ITS
- Remote monitoring
- LoRaWAN

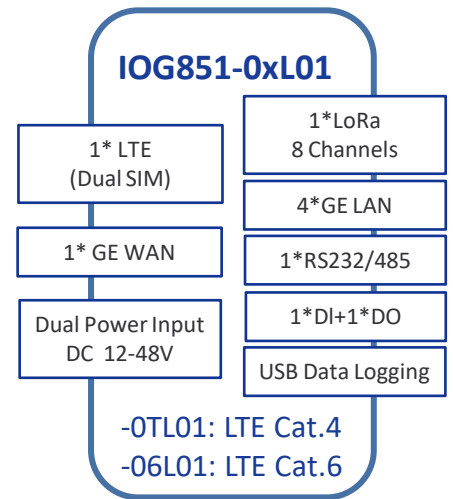

Industrial IoT & cloud integration

- LoRa Gateway, Network Server
- HTTP, MQTT, Modbus TCP/RTU/ASCII

Data & access security

- VPN, Firewall; TR-069, SNMP Remote
- VLAN grouping, I/O ports disablement

Robust low-latency networking

- Multi-WAN Failover / Load Balance
- 4G, Gigabit Ethernet

Open platform for developers

- Python programming
- AMIT Linux SDK

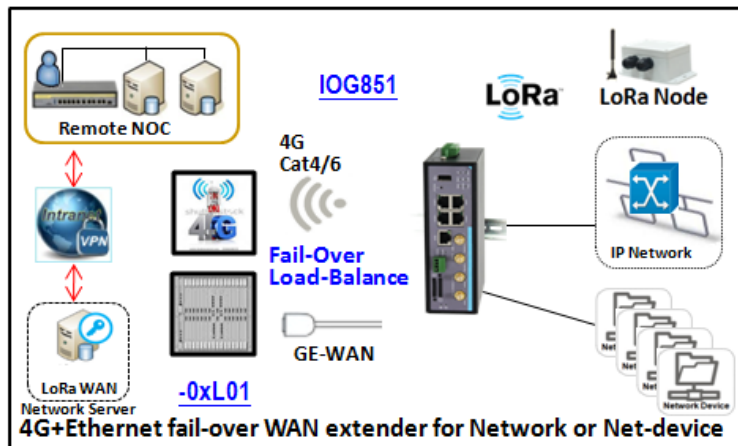
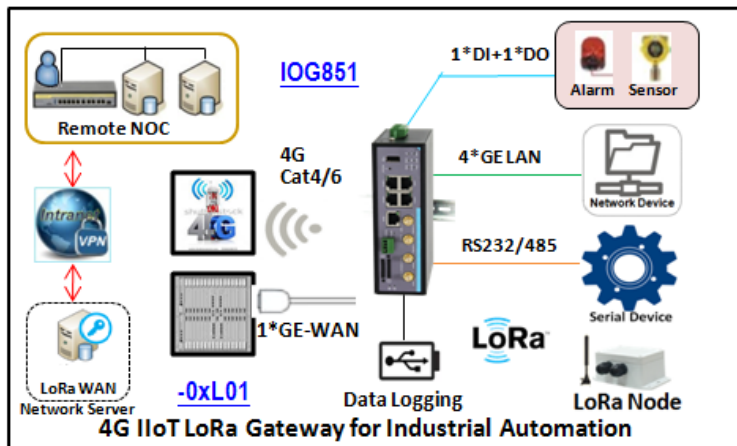

Specification Summary

Device Interface

- **4G Module:** 1*4G, 2*SIM
- **Ethernet:** 5*RJ45 GE
- **LoRa:** 1*LoRa (8*Channel)
- **Field Bus:** 1*RS232/485 (Terminal Block)
- **Log Storage:** 1*USB
- **I/O:** 1*DI ("Logic 0": 0~2V, "Logic 1": 5V~30V), 1*DO (Relay Mode, up to 30V/1A)
- **Power Input :** 2* DC 12V ~ 48V (Terminal Block)
- **Antenna Con.:** 2*SMA (F)-4G, 1*SMA(F)-LoRa

WAN & Uplink

- **WAN:** Cellular & Config. Ether-WAN; Failover, Load Balance
- **Cellular:** 3GPP, 2G/3G/4G, IP Pass-through, IPv4/6
- **Ether-WAN:** Dynamic IP, Static IP, PPPoE , PPTP, L2TP
- **Network Monitor:** ICMP/DNS Query

Protocol

- **LAN & VLAN:** DHCP Server/Relay, Port/Tag based VLAN
- **IPv6:** Dual Stack, Static IPv6, DHCPv6, PPPoEv6
- **Port Forward:** NAT 1-1, 1-many, transversal, DMZ, Virtual Server & Computer, VPN Pass-through
- **Routing:** Static, Dynamic - RIP1/RIP2, OSPF, BGP
- **QoS:** Policy-based, 802.1q and TOS for priority queues

Field Comm.

- **Virtual COM:** RFC2217, TCP Client, TCP Server, UDP
- **Modbus:** Gateway for Modbus TCP/RTU/ASCII Master/Slave Access; Slave for Device Status/Information Access
- **Data Interchange:** OPC UA Server, MQTT Broker, MQTT Client
- **Data Logging:** Sniffer, Off-line / Full-time Proxy, mixed modes

Object

- **Scheduling:** Time Schedule List
- **Grouping:** Host Grouping List
- **Ext. Server:** Email, Syslog, RADIUS, SCEP, FTP, DDNS, IGMP
- **Certificate:** My Certificate, Trusted Certificate, Issue Certificate

Security

- **VPN Tunneling:** IPSec, OpenVPN, PPTP, L2TP, GRE
- **Scenario:** Site/Host to Site/host; Hub and Spoke; Dynamic VPN
- **VPN Capability:** IPSec: up to 16 tunnels
- **Firewall:** SPI Firewall with Stealth Mode, IPS
- **Access Control:** Packet Filter, URL Blocking, MAC Filter

Administration

- **Configuration:** Web UI, CLI, Command Script, Python*
- **Management:** SNMPv3 Std. & AMIT MIB, TR069
- **System:** Upgrade, Backup & Restore, Reboot & Reset, SysLog
- **FTP:** FTP Server, User Account
- **Diagnostic:** Packet Analyzer, Diagnostic Tools

Service

- **Cellular Toolkit:** Data Usage, SMS, SIM PIN, USSD, Network Scan
- **Event Handling:** User Defined Manage/Notify Event; Action & Trigger by SMS, Mail, Syslog, SNMP Trap, Modbus, I/O
- **LoRa:** LoRa Gateway, Public Network Server (external), Private Network Server (internal, up to 300 nodes)

Environment

- **OP/Storage Temp.:** -30°C ~ 70°C ; -40°C ~ 85°C
- **Humidity:** 10%~95% (non-condensing)
- **Enclosure:** Metal, DIN-Rail, Bracket (Optional)
- **Dimension:** 62x125x160mm (w/o mounting kit)
62x135x160mm (with DIN Rail kit)

Certificate - CE

- Standards & Regulation
- EMI: EN 55032: 2015 +AC: 2016 Class B
- EMS: EN 55024, IEC 61000,
- Radio: EN 301 489, EN 300 328 ,EN 301 893, EN50385
- Safety: EN 60950-1

Package Accessory

- 1*Device
- 1*Terminal Block (8-pin for DC Power & DI/DO)
- 1*Terminal Block (4-pin for serial port)
- 1*RJ45 Cable
- 1*DIN Rail Kit, 1*Screw Bag, 1*CD (User Manual)

SKU Information:

IOG851-0TL01-00-yy : LTE Cat.4

IOG851-06L01-00-yy : LTE Cat.6

'yy': Area Variant. As below table

yy	SKU	Cellular Band	Module Cert.	System Cert.	LoRa Band (MHz)
E0	EU	B1/3/7/8/20	CE, GCF	CE	863 - 870
Ro	Russia	B3/7/20	-	EAC	863 - 870
U0	US	B2/4	PTCRB, AT&T	TBD	902 - 928
J0	Japan	B1/9/18/19/21	Telec, NTT, KDDI	Telec	923 - 925
J1	Japan	B1/8/41	Telec, Softbank	Telec	923 - 925
T0	Taiwan	B3/7/8/28	NCC	TBD	923 - 925
C0	China	B3/8/39/40/41	MII, SRRC	TBD	N/A
A0	Australia	B1/3/5/7/28/40	RCM	TBD	915 - 928

Comment:

- Specifications are subject to change without prior notice.
- Besides CE, other regional certification needs to be checked for availability.
- Supported cellular & LoRa frequency depends on regional hardware version.

Mechanic Drawing

(1) Front View



(2) Left View



m2m Germany GmbH

Am Kappengraben 18-20
61273 Wertheim

TEL: +49 (6081) 587 3860 FAX: +49 (6081) 587 3869

www.m2mgermany.de