

# Datasheet

BT900-US-0x

Intelligent USB BT/BLE Dongle Featuring *smartBASIC*

*Version 1.5*

---

## REVISION HISTORY

Version	Date	Notes	Approver
1.0	23 Feb 2015	Initial Release	Jonathan Kaye
1.1	08 July 2016	Changed Hardware Integration Guide references to Datasheet	Sue White
1.2	30 Aug 2016	Updated Declarations of Conformity	Sue White
1.3	10 Nov 2016	Fixed section numbering	Sue White
1.4	05 May 2017	Updated Declaration of Conformity section with RED standards	Tom Smith
1.5	05 Mar 2019	Updated template, logos, and URLs	Sue White

# 1 CONTENTS

1	Overview and Key Features	4
1.1	Features and Benefits	4
1.2	Application Areas	4
2	Specification	5
2.1	Specification Summary	5
3	Hardware Specifications	6
3.1	Block Diagram	6
3.2	Internal UART, nAutoRUN, and LED Wiring Definitions	6
3.2.1	USB Interface Connector	6
3.2.2	4-Wire UART Serial Interface	6
3.3	Electrical Specifications	8
3.3.1	Absolute Maximum Ratings	8
3.3.2	Recommended Operating Parameters	8
4	Functional Description	8
4.1	Power Management (includes brownout and power on reset)	8
4.2	Clocks and Timers	8
4.2.1	Clocks	8
4.2.2	Timers	9
4.3	Memory for <i>smart</i> BASIC Application Code and Data	9
4.4	RF	9
4.5	UART Interface	9
4.6	nAutoRUN Pin	9
4.7	<i>smart</i> BASIC Application Loading	10
4.8	<i>smart</i> BASIC Runtime Engine Firmware Upgrade	10
4.9	BT900-US uses the BT900-SA on-board chip antenna characteristics	10
5	Mechanical Details	10
5.1	BT900-US Mechanical Details	10
6	Product Label	11
7	FCC and IC Regulatory Statements	11
7.1	Power Exposure Information	11
7.2	Federal Communication Commission Interference Statement	11
7.3	Industry Canada Statement	12
8	EU Declarations of Conformity	13
9	Ordering Information	14
9.1	General Comments	14
10	Bluetooth SIG Qualification	14
11	Additional Assistance	15

# 1 OVERVIEW AND KEY FEATURES

The BT900-US USB Dongle has been developed to take advantage of the BT900-SA module, providing a simple and easy way to add Classic Bluetooth, BLE Central, and BLE Peripheral mode to virtually ANY operating system with a USB interface. Leverage the BT900-US to enable any Bluetooth SPP device or BLE sensor to communicate to any PC, laptop, or mobile computer without any complicated installation or software support requirements. The fully-approved, programmable dongle features Laird's innovative, event-driven *smartBASIC* programming language which significantly reduces OEM development risk and speeds time to market.

Based on the Cambridge Silicon Radio (CSR) 8811 silicon and a low power Cortex M3 microcontroller, the BT900-US provides exceptionally low power consumption with outstanding wireless range. The dongle incorporates all hardware and firmware required to support Bluetooth dual-mode applications in a computing environment including:

- Complete, packaged radio hardware
- Simple, universal USB to Virtual COM port emulation via FTDI 232R chip
- Embedded BTv4.0 software stack
  - Classic BT profile - SPP
  - GATT Client and Peripheral modes

What makes the modules truly innovative is *smartBASIC*, an event-driven programming language that enables standalone operation of the dongle. Laird has extended the implementation of *smartBASIC* from the popular BL6xx series of single-mode BLE modules into the BT900 series of modules and now the BT900-US dongle. This allows developers the flexibility of using the Core and BLE-specific *smartBASIC* functions from the BL6xx series to create fully interchangeable BLE applications between these product ranges.

Without the need for any external processor, a simple *smartBASIC* application encapsulates the complete end-to-end process of reading, writing, and processing of sensor data and then using Classic Bluetooth or BLE to transfer it to/from any Bluetooth device. Ultimately *smartBASIC* accelerates initial development, creation of prototypes, and mass production by providing you with your own Bluetooth expert within the device.

In addition to carrying FCC modular, IC, and CE approvals, the BT900-US is qualified by the Bluetooth SIG which enables designers to integrate the dongle without the need for further Bluetooth testing.

## Features and Benefits

- Bluetooth v4.0 – dual-mode (Classic Bluetooth and BLE)
- Integrated antenna
- *smartBASIC* programming language
- Compact footprint
- Programmable TX power 8dBm to -20dBm
- RX sensitivity: -90dBm
- Ultra low power consumption
- UART, LED
- Fast time to market
- FCC, CE, BT and IC certified
- No external Bluetooth stack or power supply required.

## Application Areas

- Medical devices
- Wellness devices
- Automotive diagnostic equipment
- Bar code scanners
- Industrial cable replacement
- Home automation

## 2 SPECIFICATION

### 2.1 Specification Summary

Table 1: Specifications

Categories	Feature	Implementation	
<b>Wireless Specification</b>	Bluetooth®	v4.0 – dual-mode	
	Frequency	2.402 - 2.480 GHz	
	Transmit Power	+ 8 dBm (maximum) Configurable down to -20 dBm	
	Receive Sensitivity	-90 dBm (typical)	
	Link Budget	98 dB	
<b>Host Interface and Peripherals</b>	Raw Data Rates (Air)	3 Mbps (Classic BT – BR/EDR)	
	USB 2.0 – UART interface	TX, RX, CTS, RTS DTR, DSR, DCD can be implemented in <i>smartBASIC</i> - using General Purpose I/O	
	Virtual COM port via FTDI232R	Default 115200, N, ,8, 1	
<b>Profiles</b>	LED	1 x User configurable via <i>smartBASIC</i>	
	Classic Bluetooth	SPP (Serial Port Profile) –Greater than 400kbps	
<b>Maximum Connections</b>	Bluetooth Low Energy	GATT Client and Peripheral – Any Custom Services	
	Classic Bluetooth	7 clients	
<b>Programmability</b>	Bluetooth Low Energy	5 clients	
	<i>smartBASIC</i>	On-board programming language similar to BASIC	
<b>Control Protocols</b>	<i>smartBASIC</i> application	Via UART	
		Any that can be implemented using <i>smartBASIC</i> VSP – Virtual Serial Port for BLE – Command Mode Only	
<b>FW upgrade</b>	<i>smartBASIC</i> runtime engine FW upgrade	Via UART	
<b>Supply Voltage</b>	Supply	5.0V +/- 10% Powered by standard USB port	
	<b>Operating Modes</b>	Self-contained Run Mode	Selected by nAutoRUN pin status: LOW (0V). Then runs \$autorun\$ ( <i>smartBASIC</i> application) if it exists. Default for BT900-US. Refer to the warning in <a href="#">Note 1</a> .
		Interactive Development Mode	HIGH (VCC). Then runs via <b>at+run</b> (and <i>file name</i> of <i>smartBASIC</i> application script).
<b>Physical</b>	Dimensions	18.39 mm x 50.74 mm x 11mm	
<b>Environmental</b>	Operating	-40°C to +85°C	
	Storage	-40°C to +85°C	
<b>Miscellaneous</b>	Lead Free	Lead-free and RoHS compliant	
	Warranty	<a href="#">Limited Lifetime Warranty</a>	
<b>Software Tools</b>	Utilities	UWTerminal or any Terminal Emulation program UART Firmware Upgrade	
	<b>Approvals</b>	Bluetooth®	HW Subsystem Declaration ID
FCC / IC / CE		Additional countries upon review	

### 3 HARDWARE SPECIFICATIONS

#### 3.1 Block Diagram

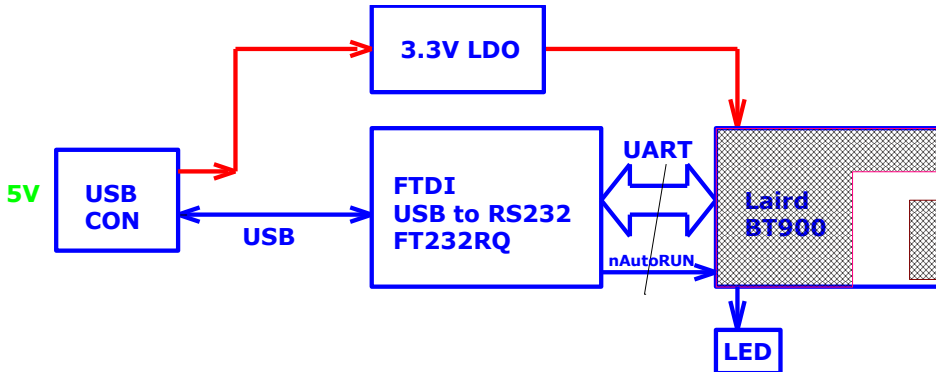

Figure 1: BT900-US block diagram

#### 3.2 Internal UART, nAutoRUN, and LED Wiring Definitions

##### 3.2.1 USB Interface Connector

The BT900-US USB connector allows a connection to any USB host device and supplies power to the BT900-US. The USB signals are connected to a USB to serial convertor device (FT232R). The BT900-US operates as a USB peripheral.

##### 3.2.2 4-Wire UART Serial Interface

The BT900-US is fitted with an FTDI FT232R USB to UART converter chip which provides a USB-to-Virtual COM port on any Windows PC. Upon connection, Windows auto-installs the required drivers. For more details and driver downloads, visit <http://www.ftdichip.com/Products/FT232R.htm>.

The Virtual COM port (BT900 UART) is used for interacting with the BT900-US as well as for loading *smartBASIC* application script or upgrading the *smartBASIC* runtime engine firmware.

The BT900-US provides access to the BT900 module 4-wire UART interface (TX, RX, CTS, RTS) through a USB (via USB-UART FTDI FT232R convertor chip).

**Note:** The BT900 module provides 4-wire UART interface to the FTDI FT232R chip. The other three signals on FTDI FT232R chip (DTR, DSR, DCD) are wired in the BT900-US to the BT900 digital SIO pins namely nAutoRUN pin, SIO\_4 and SIO\_5 respectively, and can be implemented on the BT900-US in a *smartBASIC* application to create DTR, DSR, DCD functionality if required.

UART connection between the BT900 module UART and FTDI FT232R IC UART are shown in Table 2.

Table 2: Internal UART and nAutoRUN wiring (inside BT900-US) between BT900 module and FTDI chip

BT900 Pin #	BT900 Pin Name	BT900 Default Funct.	BT900 Alternate Funct.	BT900 Default Direction	BT900 Internal Pull-up or Pull-down State	FTDI IC UART	FTDI IC UART Direction	Comments and Notes
44	UART_RX	DIO	SIO_0	IN	Pull-up	USB_TX	OUT	
45	UART_TX	DIO	SIO_1	OUT	Set high in FW	USB_RX	IN	
46	UART_RTS	DIO	SIO_2	OUT	Set low in FW	USB_CTS	IN	
1	UART_CTS	UART	SIO_3	IN	Pull-up	USB_RTS	OUT	
3	nAutoRUN		SIO_22	IN	Pull-up	USB_DTR	In	Note 1

**Table 3: Internal SIO\_4, SIO\_5 wiring (inside BT900-US) between BT900 module and FTDI chip**

Pin #	Pin Name	Default Funct.	Alternate Funct.	Default Direction	Internal Pull-up or Pull-down State	FTDI IC UART	FTDI IC UART Direction	Comments and Notes
2	SIO_4	DIO	-	IN	Pull-up	USB_DSR	IN	Note 2
4	SIO_5	DIO	-	IN	Pull Up	USB_DCD	IN	Note 2

**Table 4: Internal wiring (inside the BT900-US) between BT900 module and LED**

Pin #	Pin Name	Default Funct.	Alternate Funct.	Default Direction	Internal Pull-up or Pull-down State	Comments and Notes	
20	SIO_17	DIO	-	IN	Pull Up	Connected to LED	Note 3

The BT900-US is delivered with the integrated *smartBASIC* runtime engine FW loaded (but no on-board the *smartBASIC* application script). In order to deliver any wireless functionality, a *smartBASIC* application needs to be loaded onto the BT900-US – a large selection of sample *smartBASIC* applications are available at <https://github.com/LairdCP/BT900-Applications>.

**Internal Wiring Notes:**

**Note 1**

The BT900 nAutoRUN input pin on the module can be driven by the DTR output pin of the FTDI FT232R chip. This enables running of the \$autorun\$ application on boot.

**WARNING:** The BT900-US by default is in autorun self-contained mode (nAutoRUN input pin is internally held LOW). If a *smartBASIC* application has been loaded with a name \$autorun\$, then the device on power up will automatically execute that application. If the autorun application has a statement to close the UART, then it is not possible to exit the autorun mode with the normal UART BREAK command. This results in the BT900-US being in the autorun state permanently (where it is running the autorun *smartBASIC* application). To bring the BT900-US out of this permanent autorun state, please follow the procedure in the BT900-US Autorun Recovery application note which can be accessed from the [BT900-US product page](#) of the Laird Embedded Wireless Support Center.

Another way to avoid getting the BT900-US into this permanent autorun state is to NOT name your *smartBASIC* application as \$autorun\$, but give it another name, in which case that *smartBASIC* application has to be manually run by calling its at+run command.

**Note 2**

In addition to the 4-wire UART interface on the BT900, there are two signals (SIO\_4 and SIO\_5) wired from the BT900 to the FTDI chip's DSR and DCD input lines. SIO\_4 and SIO5 are not driven by the BT900 as their default direction is an input. If the customer requires DCD and DSR functionality on the BT900-US, then the customer will need to implement that in their *smartBASIC* application.

**Note 3**

LED is connected to BT900 module pin SIO\_17. The LED is active high, meaning that writing a logical one ("1") to the output pin illuminates the LED.

Apart from the above mentioned SIO pins of the BT900 module, all remaining BT900 pins inside the BT900-US are unconnected.

**Note 4**

BT900-US does not have hardware reset line, but can be reset with the BREAK command (using UWTerminal). By default, the BT900-US is out of reset.

### 3.3 Electrical Specifications

#### 3.3.1 Absolute Maximum Ratings

Absolute maximum ratings for supply voltage and voltages on digital and analogue pins of the module are listed below. Exceeding these values causes permanent damage.

**Table 5: Maximum current ratings**

Parameter	Min	Max	Unit
Voltage at USB_VCC pin	4.0	+5.5V	V
DC input voltage USB+ and USB-		+3.8	V
Storage temperature	-40	+85	°C

#### 3.3.2 Recommended Operating Parameters

**Table 6: Power supply operating parameters**

Parameter	Min	Typ	Max	Unit
USB_VCC (Note 1)	4.75V	5	5.25V	V
Operating Temperature Range	-40	-	+85	°C

**Note 1:** BT900-US does not have a hardware reset line, but can be reset with BREAK command (use UWTerminal). By default the BT900-US is out of reset. BT900 module start-up time is ~1.6 seconds; start-up time is the time taken from power-up to being able to run a *smartBASIC* command. Most of this is for radio initialization. 1.6 seconds is also the time when coming out of reset through AT command (atz) or AT command for factory default (at&f\*).

## 4 FUNCTIONAL DESCRIPTION

The BT900-US uses the BT900 module which is interfaced to FTDI FT232R USB to the UART converter chip.

The BT900 dual-mode (BT/BLE) module is a self-contained BT and Bluetooth Low Energy (BLE) product and requires only power and a user's *smartBASIC* application to implement full BT/BLE functionality. The integrated, high performance antenna combined with the RF and base-band circuitry provides the Bluetooth or BLE wireless link.

The BT900-US provides access to the below BT900 module functional blocks.

### 4.1 Power Management (includes brownout and power on reset)

BT900 module power management features:

- System Standby Doze/Deep Sleep modes
- Brownout Reset
- Open/Close peripherals (UART) with a command in a *smartBASIC* application script
- Pin Wake-Up system from Deep Sleep
- Supervisor HW to manage power on reset, brownout (and power fail).
- BT900-US 5V operating supply.

### 4.2 Clocks and Timers

#### 4.2.1 Clocks

The BT900 module integrated high accuracy (+/-20 ppm) 32.768 kHz crystal oscillator provides protocol timing and helps with radio power consumption in the system Standby Doze/Deep sleep modes by reducing the time that the RX window must be open.

The integrated high accuracy 26 MHz (+/-10 ppm) crystal oscillator helps with radio operation and also helps reduce power consumption in the Active modes.



## 4.2.2 Timers

In keeping with the event driven paradigm of *smartBASIC*, the timer subsystem enables the writing of *smartBASIC* which allows the generation of future events based on timeouts.

- Regular Timer – There are eight built-in timers (regular timer) derived from a single RTC clock which are controlled solely by *smartBASIC* functions. The resolution of the regular timer is 488 microseconds.
- Tick Timer – This is a 31-bit free running counter that increments every one millisecond. The resolution of this counter is 488 microseconds. It can be accessed using the functions `GetTickCount()` and `GetTickSince()`.

Refer to the BT900 *smartBASIC User Guide* for more information.

## 4.3 Memory for *smartBASIC* Application Code and Data

Up to approximately 48 Kb of data memory is available for the *smartBASIC* application script and up to 4 Kb is available for data.

## 4.4 RF

- 2402–2480 MHz Bluetooth 4.0 Dual Mode (BT and BLE); 1 Mbps to 3 Mbps over the air data rate
- TX output power of +8 dBm programmable (via *smartBASIC* command) to -20 dBm in steps of 4dB
- Receiver (with integrated channel filters) to achieve maximum sensitivity -90 dBm @ 1 Mbps BLE or Classic BT, 2 Mbps, 3 Mbps)
- Integrated monopole chip antenna on the BT900-SA

## 4.5 UART Interface

The Virtual COM port (BT900 UART) is used for interacting with BT900-US as well as loading *smartBASIC* application script or upgrading the *smartBASIC* runtime engine FW.

The BT900 Universal Asynchronous Receiver/Transmitter (UART) offers fast, full-duplex, asynchronous serial communication with built-in flow control support (UART\_CTS, UART\_RTS) in hardware up to 2 Mbps baud. No parity checking, 8 data bits, and 1 stop bit are supported. Customers must use HW flow control when operating the BT900-US.

UART\_TX, UART\_RX, UART\_RTS, and UART\_CTS form a conventional asynchronous serial data port with handshaking. The interface is designed to operate correctly when connected to other UART devices such as the 16550A. The signalling levels are nominal 0 V and 3.3 V and are inverted with respect to the signalling on an RS232 cable.

Two-way hardware flow control is implemented by UART\_RTS and UART\_CTS. UART\_RTS is an output and UART\_CTS is an input. Both are active low.

These signals operate according to normal industry convention. UART\_RX, UART\_TX, UART\_CTS, and UART\_RTS are 3.3 V level logic. For example, when RX and TX are idle they sit at 3.3 V. Conversely for handshaking pins CTS, RTS at 0 V is treated as an assertion.

UART has a deep buffer (UART\_RX deep buffer) of 1024 bytes.

## 4.6 nAutoRUN Pin

BT900-US provides, through the virtual COM Port, access to the nAutoRUN pin that can be used to select operating modes (refer to the *smartBASIC User Guide* for details):

- Self-contained mode
- Interactive / Development mode (BT900-US default)

nAutoRUN is an input, with active low logic. In the BT900-US it is connected so that the state is driven by the FTDI 232R chip DTR output line. nAutoRUN pin is held high or low to select between the following two BT900 operating modes:

- Self-contained Run mode (nAutoRUN pin held at 0 V)
- Interactive / development mode (nAutoRUN pin held at VCC)

The *smartBASIC* runtime engine firmware checks for the status of nAutoRUN during power-up or reset. If it is low AND if there is a *smartBASIC* application script named **\$autorun\$**, then the *smartBASIC* runtime engine FW executes the application script

automatically; hence the name Self-Contained Run Mode. The default in the BT900-US is that the nAutoRUN pin is held Low, so BT900-US is in autorun self-contained mode.

If a customer is required to come out of self-contained autorun mode (nAutoRUN driven low), refer to the section 3.2 [Note1](#) on how to bring the BT900-US out of the permanent autorun state and follow the procedure in the BT900-US Autorun Recovery application note which can be accessed from the [BT900-US product page](#) of the Laird Embedded Wireless Support Center.

## 4.7 smartBASIC Application Loading

The BT900 smartBASIC application script developed by the customer can be loaded through the UART interface.

## 4.8 smartBASIC Runtime Engine Firmware Upgrade

BT900 smartBASIC runtime engine FW (loaded at production, may be upgraded by the customer through the UART).

## 4.9 BT900-US uses the BT900-SA on-board chip antenna characteristics

The BT900-US uses the BT900-SA module that has an on-board chip monopole antenna

BT900-SA on-board antenna datasheet: [http://www.acxc.com.tw/product/at/at3216/AT3216-B2R7HAA\\_S-R00-N198\\_2.pdf](http://www.acxc.com.tw/product/at/at3216/AT3216-B2R7HAA_S-R00-N198_2.pdf)

# 5 MECHANICAL DETAILS

## 5.1 BT900-US Mechanical Details

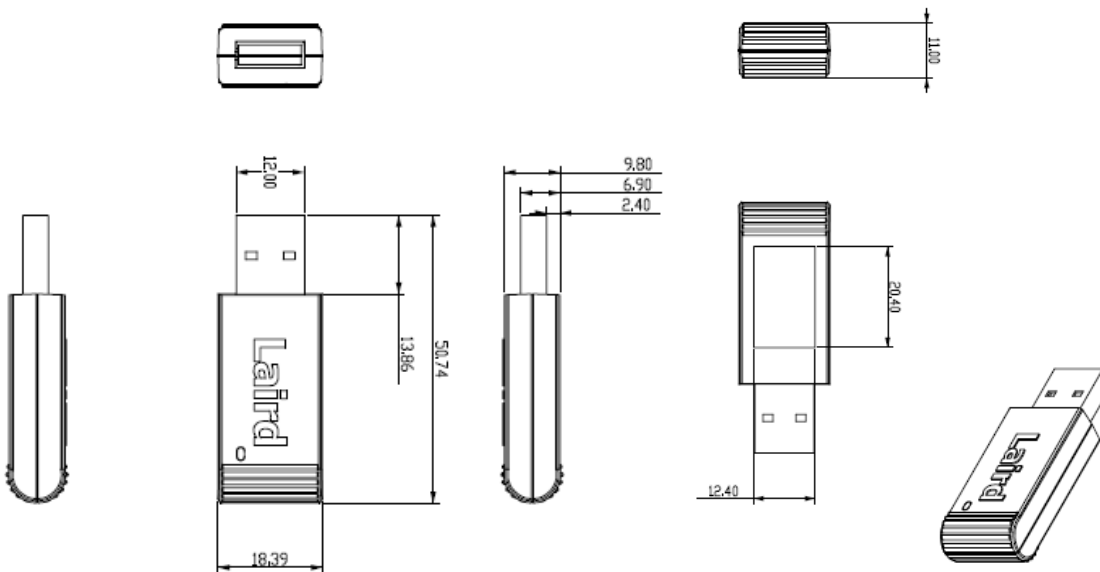
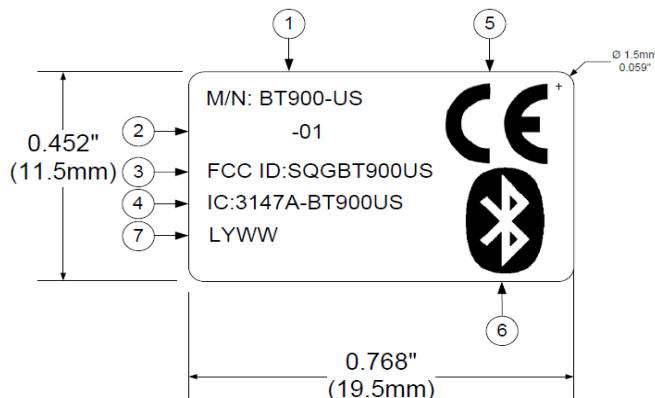

Figure 2: BT900-US Mechanical drawings

## 6 PRODUCT LABEL



- |                            |   |
|----------------------------|---|
| 1. Product model number    | 6. Bluetooth logo                             |
| 2. Product revision number | 7. Serial number:                             |
| 3. FCC ID                  | ▪ L = Location                                |
| 4. IC ID                   | ▪ Y = Year code (ref. 0010-00083 latest rev.) |
| 5. CE logo                 | ▪ WW = Week of the year                       |

Base material (blank label material specification):

- Material: Polyimide (stable @ 260°C)
- Color: Glossy white
- Text: Black
- Corners: Max. acceptable radius = 1.5 mm (0.125 inches)

## 7 FCC AND IC REGULATORY STATEMENTS

Model	US/FCC	CANADA/IC
BT900-US	SQGBT900US	3147-BT900US

Part #	Form Factor	TX Output	Antenna
BT900-US	USB Dongle	8 dBm	Ceramic, Integrated

### 7.1 Power Exposure Information

Federal Communication Commission (FCC) Radiation Exposure Statement:

This EUT is in compliance with SAR for general population/uncontrolled exposure limits in ANSI/IEEE C95.1-1999 and had been tested in accordance with the measurement methods and procedures specified in OET Bulletin 65 Supplement C.

This transceiver must not be co-located or operating in conjunction with any other antenna, transmitter, or external amplifiers. Further testing / evaluation of the end product will be required if the OEM's device violates any of these requirements.

The BT900 is fully approved for mobile and portable applications.

### 7.2 Federal Communication Commission Interference Statement

This equipment has been tested and found to comply with the limits for a Class B digital device, pursuant to Part 15 of the FCC Rules. These limits are designed to provide reasonable protection against harmful interference in a residential installation. This equipment generates, uses and can radiate radio frequency energy and, if not installed and used in accordance with the instructions, may cause harmful interference to radio communications. However, there is no guarantee that interference will not occur in a particular installation. If this equipment does cause harmful interference to radio or television reception, which can be determined by turning the equipment off and on, the user is encouraged to try to correct the interference by one of the following measures:

- Reorient or relocate the receiving antenna.
- Increase the separation between the equipment and receiver.

- Connect the equipment into an outlet on a circuit different from that to which the receiver is connected.
- Consult the dealer or an experienced radio/TV technician for help.

**FCC Caution:**

Any changes or modifications not expressly approved by the party responsible for compliance could void the user's authority to operate this equipment.

This device complies with Part 15 of the FCC Rules. Operation is subject to the following two conditions: (1) This device may not cause harmful interference, and (2) this device must accept any interference received, including interference that may cause undesired operation.

**IMPORTANT NOTE:**

**FCC Radiation Exposure Statement:**

The product comply with the US portable RF exposure limit set forth for an uncontrolled environment and are safe for intended operation as described in this manual. The further RF exposure reduction can be achieved if the product can be kept as far as possible from the user body or set the device to lower output power if such function is available.

This transmitter must not be co-located or operating in conjunction with any other antenna or transmitter.

## 7.3 Industry Canada Statement

This device complies with Industry Canada's licence-exempt RSSs. Operation is subject to the following two conditions:

(1) This device may not cause interference; and (2) This device must accept any interference, including interference that may cause undesired operation of the device.

Cet appareil est conforme aux CNR exemptes de licence d'Industrie Canada. Son fonctionnement est soumis aux deux conditions suivantes:

(1) Ce dispositif ne peut causer d'interférences; et(2) Ce dispositif doit accepter toute interférence, y compris les interférences qui peuvent causer un mauvais fonctionnement de l'appareil.

**Radiation Exposure Statement:**

The product comply with the Canada portable RF exposure limit set forth for an uncontrolled environment and are safe for intended operation as described in this manual. The further RF exposure reduction can be achieved if the product can be kept as far as possible from the user body or set the device to lower output power if such function is available.

**Déclaration d'exposition aux radiations:**

Le produit est conforme aux limites d'exposition pour les appareils portables RF pour les Etats-Unis et le Canada établies pour un environnement non contrôlé. Le produit est sûr pour un fonctionnement tel que décrit dans ce manuel. La réduction aux expositions RF peut être augmentée si l'appareil peut être conservé aussi loin que possible du corps de l'utilisateur ou que le dispositif est réglé sur la puissance de sortie la plus faible si une telle fonction est disponible.

## 8 EU DECLARATIONS OF CONFORMITY

<b>Manufacturer:</b>	Laird
<b>Products:</b>	BT900-US
<b>Product Description</b>	2.4 GHz Bluetooth v4.0 Dual Dongle
<b>EU Directives</b>	2014/53/EU – Radio Equipment Directive (RED)



### Reference standards used for presumption of conformity:

Article Number	Requirement	Reference standard(s)
3.1a	Low voltage equipment safety	EN 60950-1:2006 +A11:2009 +A1:2010 +A12:2011 +A2:2013
	RF Exposure	EN 62311:2008
3.1b	Protection requirements with respect to electromagnetic compatibility	EN 301 489-1 v2.2.0 (2017-03) EN 301 489-17 v3.2.0 (2017-03)
3.2	Means of the efficient use of the radio frequency spectrum	EN 300 328 v2.1.1 (2016-11)

### Declaration:

We, Laird, declare under our sole responsibility that the essential radio test suites have been carried out and that the above product to which this declaration relates is in conformity with all the applicable essential requirements of Article 3 of the EU Radio Equipment Directive 2014/53/EU, when used for its intended purpose.

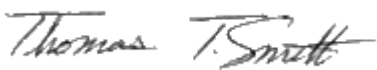
Place of Issue:	Laird W66N220 Commerce Court, Cedarburg, WI 53012 USA tel: +1-262-375-4400 fax: +1-262-364-2649
Date of Issue:	May 2017
Name of Authorized Person:	Thomas T Smith, Director of EMC Compliance
Signature of Authorized Person:	

## 9 ORDERING INFORMATION

Part Number	Description
BT900-US-0x	Intelligent USB BT / BLE Dongle featuring smartBASIC

### 9.1 General Comments

This is a preliminary datasheet. Please check with Laird for the latest information before commencing a design. If in doubt, ask.

## 10 BLUETOOTH SIG QUALIFICATION

The BT900-US module is listed on the Bluetooth SIG website as qualified End Products.

Design Name	Owner	Declaration ID	Link to listing on the SIG website
BT900-US	Laird	D023116	<a href="https://www.bluetooth.org/tpg/QLI_viewQDL.cfm?qid=23116">https://www.bluetooth.org/tpg/QLI_viewQDL.cfm?qid=23116</a>

It is a mandatory requirement of the Bluetooth Special Interest Group (SIG) that every product implementing Bluetooth technology has a Declaration ID. Every Bluetooth design is required to go through the qualification process, even when referencing a Bluetooth Design that already has its own Declaration ID. The Qualification Process requires each company to register as a member of the Bluetooth SIG – [www.bluetooth.org](http://www.bluetooth.org)

The following link provides a link to the Bluetooth registration page: <https://www.bluetooth.org/login/register/>

For each Bluetooth Design it is necessary to purchase a Declaration ID. This can be done before starting the new qualification, either through invoicing or credit card payment. The fees for the Declaration ID will depend on your membership status, please refer to the following webpage:

<https://www.bluetooth.org/en-us/test-qualification/qualification-overview/fees>

For a detailed procedure of how to obtain a new Declaration ID for your design, refer to the following document: [https://www.bluetooth.org/DocMan/handlers/DownloadDoc.ashx?doc\\_id=283698&vId=317486](https://www.bluetooth.org/DocMan/handlers/DownloadDoc.ashx?doc_id=283698&vId=317486)

To start the listing, go to: [https://www.bluetooth.org/tpg/QLI\\_SDoc.cfm](https://www.bluetooth.org/tpg/QLI_SDoc.cfm)

In step 1, select the option, **Reference a Qualified Design** and enter xXXXX in the End Product table entry. You can then select your pre-paid Declaration ID from the drop down menu or go to the Purchase Declaration ID page.

**Note:** Unless the Declaration ID is pre-paid or purchased with a credit card, you cannot proceed until the SIG invoice is paid.

Once all the relevant sections of step 1 are finished, complete steps 2, 3, and 4 as described in the help document. Your new Design will be listed on the SIG website and you can print your Certificate and DoC.

For further information please refer to the following training material:

<https://www.bluetooth.org/en-us/test-qualification/qualification-overview/listing-process-updates>

## 11 ADDITIONAL ASSISTANCE

Please contact your local sales representative or our support team for further assistance:

Laird Technologies Connectivity Products Business Unit  
Support Center: <https://connectivity.lairdtech.com/resources/support>

Email: [wireless.support@lairdtech.com](mailto:wireless.support@lairdtech.com)

Phone: Americas: +1-800-492-2320  
Europe: +44-1628-858-940  
Hong Kong: +852 2923 0610

Web: <https://connectivity.lairdtech.com/wireless-modules/bluetooth-modules>

© Copyright 2017 Laird. All Rights Reserved. Patent pending. Any information furnished by Laird and its agents is believed to be accurate and reliable. All specifications are subject to change without notice. Responsibility for the use and application of Laird materials or products rests with the end user since Laird and its agents cannot be aware of all potential uses. Laird makes no warranties as to non-infringement nor as to the fitness, merchantability, or sustainability of any Laird materials or products for any specific or general uses. Laird, Laird Technologies, Inc., or any of its affiliates or agents shall not be liable for incidental or consequential damages of any kind. All Laird products are sold pursuant to the Laird Terms and Conditions of Sale in effect from time to time, a copy of which will be furnished upon request. When used as a tradename herein, *Laird* means Laird PLC or one or more subsidiaries of Laird PLC. Laird™, Laird Technologies™, corresponding logos, and other marks are trademarks or registered trademarks of Laird. Other marks may be the property of third parties. Nothing herein provides a license under any Laird or any third party intellectual property right.