

Datasheet

Sterling-EWB

Version 1.0

REVISION HISTORY

Version	Date	Notes	Contributor(s)	Approver
0.1	29 Mar 2019			Jay White

CONTENTS

1	Scope	4
2	Introduction.....	4
2.1	General Description.....	4
2.2	Features Summary.....	4
2.3	Applications.....	5
3	Module Variants.....	5
4	Ordering Information.....	6
4.1	Module Accessories	7
5	Block Diagram	8
6	Base SiP Module Footprint and Pin Definitions	9
7	U.FL/Chip Antenna Module Footprint and Pin Definitions	15
8	Specifications	19
8.1	General Characteristics.....	19
8.2	Power Supply Requirements.....	19
8.2.1	RF Characteristics.....	19
8.3	Maximum Ratings	20
8.4	WLAN Power Consumption.....	20
8.5	Bluetooth Power Consumption.....	20
8.6	WLAN RF Characteristics	21
8.7	Bluetooth RF Characteristics.....	23
9	MCU Interface Characteristics.....	24
9.1	DC Characteristics – General Input and Output.....	24
9.2	I2C Interface.....	25
9.3	SPI Interface	26
10	MCU UART Interfaces.....	27
10.1	Overview	27
10.2	Soldering Recommendations	27
10.3	Recommended Reflow Profile for Lead Free Solder	27
11	Wi-Fi MAC IDs/Bluetooth MAC IDs	28
12	Mechanical Details	28
12.1	Base SiP Module Mechanical Data	28
12.2	Base SiP Module PCB Footprint	29
12.3	Base SiP Module Recommended Solder Stencil	30
12.4	Base SiP Module Tape and Reel Packaging.....	31
12.5	U.FL and Chip Antenna PCB Footprint	32
12.6	U.FL and Chip Antenna Tape and Reel Packaging.....	33
12.7	Device Markings.....	33
12.7.1	SiP Module	33
12.7.2	Antenna Option Modules.....	33
13	Cleaning	34
14	Optical Inspection.....	34
15	Rework	34
16	Shipping, Handling, and Storage.....	34
17	Regulatory	35
17.1	FCC and IC Regulatory – Pending.....	35
17.2	Europe – EU Declaration of Conformity	38
17.3	Japan (MIC) Regulatory	38
17.4	Australia and New Zealand	38
18	Bluetooth SIG Qualification	39
18.3	Additional Assistance	40

1 SCOPE

This document describes key hardware aspects of the Laird Connectivity Sterling-EWB.

2 INTRODUCTION

2.1 General Description

The Laird Connectivity Sterling-EWB is a high performance 2.4 GHz WLAN and Bluetooth combo module based on latest-generation silicon (Cypress's CYW4343W) with an integrated ST Micro STM32F412 Cortex M4 MCU. With an industrial temperature rating, broad country certifications, and the availability of three different package styles, the Sterling-EWB provides significant flexibility to meet various end user application needs.

The on-module chip antenna package style for the Sterling-EWB eliminates complexity for design integration, simplifies manufacturing assembly with larger pin outs, and features an advanced chip antenna that offers greater resistance to de-tuning than typical trace or chip antennas.



2.2 Features Summary

- IEEE 802.11 b/g/n (single stream n)
- Bluetooth v4.2 BR/DR/LE
- Cortex M4 microprocessor
- Typical WLAN transmit power:
 - +17.5 dBm, 11 Mbps, CCK (b)
 - +14.0 dBm, 54 Mbps, OFDM (g)
 - +12.5 dBm, HT20 MCS7 (n)
- Typical WLAN sensitivity:
 - -88 dBm, 8% PER, 11 Mbps (b)
 - -75 dBm, 10% PER, 54 Mbps (g)
 - -72 dBm, 10% PER, MCS7 (n)
- WLAN and Bluetooth coexistence
- Available in two footprint styles:
 - Easy to Integrate: 16 mm x 21 mm
 - Miniature footprint: 10 mm x 10 mm
- Available with integrated chip antenna or U.FL connector for external antenna
- Operating voltage: 3.0V to 3.6V
- Operating temperature: -40° to +85° C
- Storage temperature: -40° to +125° C
- Compact design based on Cypress CYW4343W SoC and STM32F412 MCU
- Worldwide acceptance pending: FCC (USA), IC (Canada), ETSI (Europe), Giteki (Japan), and RCM (AU/NZ)
- BT SIG QDID: TBD
- REACH and RoHS-compliant

WLAN

- IEEE 802.11b/g/n 1x1 2.4 GHz radio
 - Internal power amplifier (PA)
 - Internal low noise amplifier (LNA)
 - Internal T/R switch
 - Simultaneous BT/WLAN reception with a single antenna.
- Media Access Controller (MAC)
- Physical Layer (PHY)
- Baseband processor
- Standards
 - IEEE 802.11b, 802.11g, 802.11n (single stream)

Bluetooth

- Class 2 power amplifier with Class 2 capability
- HCI interface using high speed UART
- PCM for audio data
- Bluetooth v4.2 BR /DR/LE

Microcontroller

- STM32 Arm 32-bit Cortex™-M4 with a frequency up to 100 MHz
- 1 MB internal flash
- 256 kB of SRAM
- 2 MB SPI flash
- SPI, QSPI, USART, PCM
- ADC, I2C, I2S, GPIO, Timers
- JTAG
- WICED Fully compatible

Wireless Security System Features – Supported Modes

- Open (no security)
- WEP
- WPA Personal
- WPA2 Personal
- WMM
- WMM-PS (U-APSD)
- WMM-SA
- WAPI
- AES (Hardware accelerator)
- TKIP (host-computed)
- CKIP (SW support)

2.3 Applications

- Security and building automation
- Internet of Things/M2M connectivity
- Smart gateways

3 MODULE VARIANTS

The Laird Connectivity Sterling-EWB module is available in three different versions. Depending on your antenna and footprint needs, there is a variant to suit most application requirements. We recommend, for simplicity of both the host PCB design and the manufacturing process, that you use either the chip antenna or RF connector version of the modules.

- **453-00012 - Base SiP Module**

This module variant is supplied in a compact, 151 pin, 0.5 mm pitch LGA footprint. Unlike the other module variants, it requires the addition of either an off-module antenna or RF connector, as well as the associated matching components. To benefit from the EMC certifications on the module, you must strictly follow the layout in the module application guide. This requires adherence to the PCB stack-up and layout around the antenna. The footprint of this module may require additional care during reflow and PCB assembly.



Figure 1 Sterling-EWB Base SiP module (453-00012)

▪ **453-00013 – U.FL Module**

This module variant integrates the 450-00012 base SiP module, a U.FL RF connector, and all associated RF matching components on a PCB. This integrated approach not only provides a U.FL connector for connections to external antennas, but also simplifies and reduces the cost of the end users host board by simplifying the module PCB footprint.



Figure 2: Sterling-EWB U.FL module (453-00013)

▪ **453-00014 - Chip Antenna Module**

This module variant integrates the 453-00012 base SiP module, a chip antenna, and all associated RF matching components on a PCB. This integrated approach not only provides an external antenna solution, but also simplifies and reduces the cost of the end users host board by simplifying the module PCB footprint.





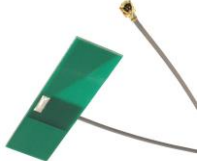

Figure 3 Sterling-EWB chip antenna module (453-00014)

4 ORDERING INFORMATION

Part Number	Description
453-00013C	Sterling-EWB U.FL module (Cut Tape)
453-00013R	Sterling-EWB U.FL module (Tape and Reel, SPQ = 1000)
453-00014C	Sterling-EWB chip antenna module (Cut Tape)
453-00014R	Sterling-EWB chip antenna module (Tape and Reel, SPQ = 1000)
453-00012C	Sterling-EWB base SiP module (Cut Tape)
453-00012R	Sterling-EWB base SiP module (Tape and Reel, SPQ = 2000)
455-00030	Sterling-EWB development kit, Chip Antenna
455-00031	Sterling-EWB development kit, FlexPIFA Antenna

4.1 Module Accessories

Part Number	Description	Image
001-0001	2.4 GHz dipole antenna with reverse polarity SMA connector	
080-0001	U.FL to reverse polarity SMA bulkhead cable 105 mm	
001-0014	2.4 GHz FlexPIFA antenna	
001-0015	2.4 GHz FlexNotch antenna	
001-0030	2.4 GHz Metal FlexPIFA antenna w/U.FL cable, 100 mm	
MAF94045	2.4 GHz NanoBlue Antenna	

5 BLOCK DIAGRAM

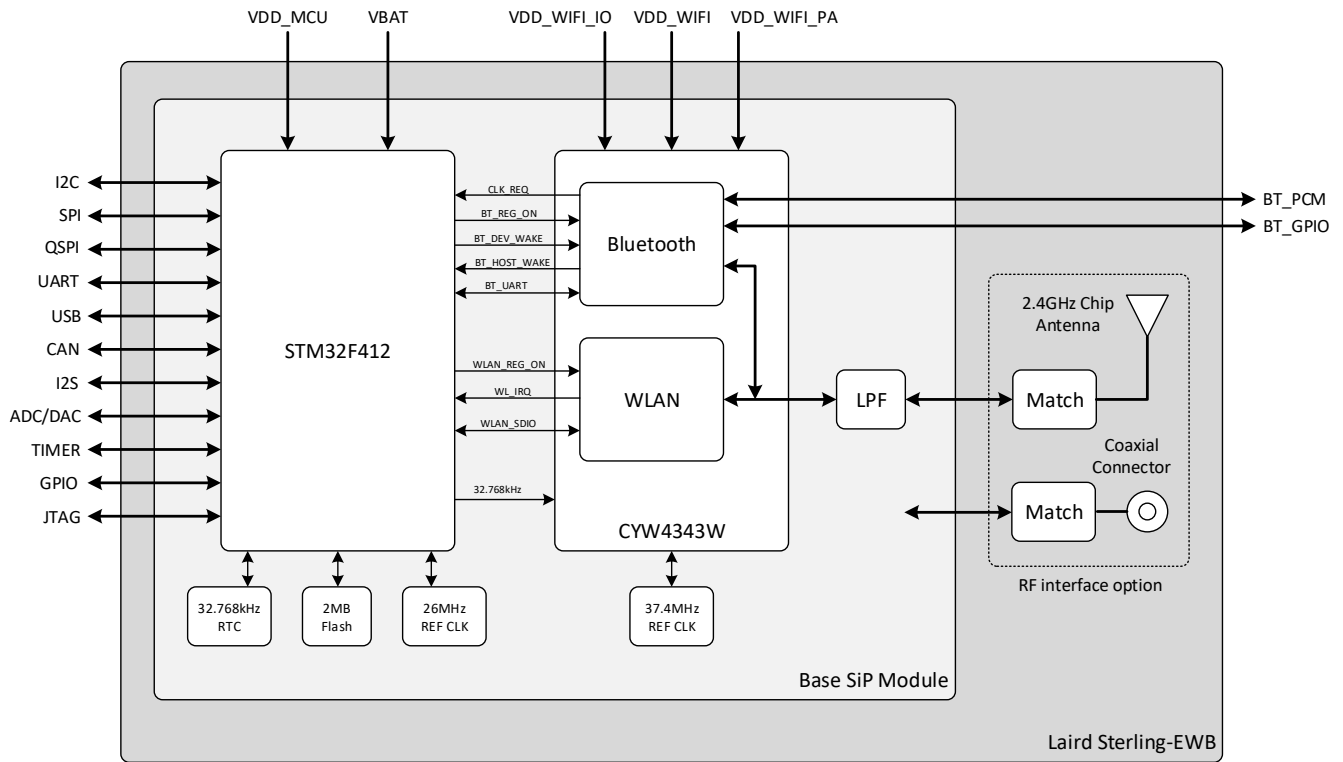

Figure 4: Sterling-EWB U.FL/chip antenna module block diagram

6 BASE SiP MODULE FOOTPRINT AND PIN DEFINITIONS

Note: The following footprint and pin definitions apply to the Sterling-EWB base SiP module (453-00012). There are two module footprints, depending on which variant of the module is used. *It is important to ensure you are using the correct version on your design.*

6.1 Base SiP Module Footprint

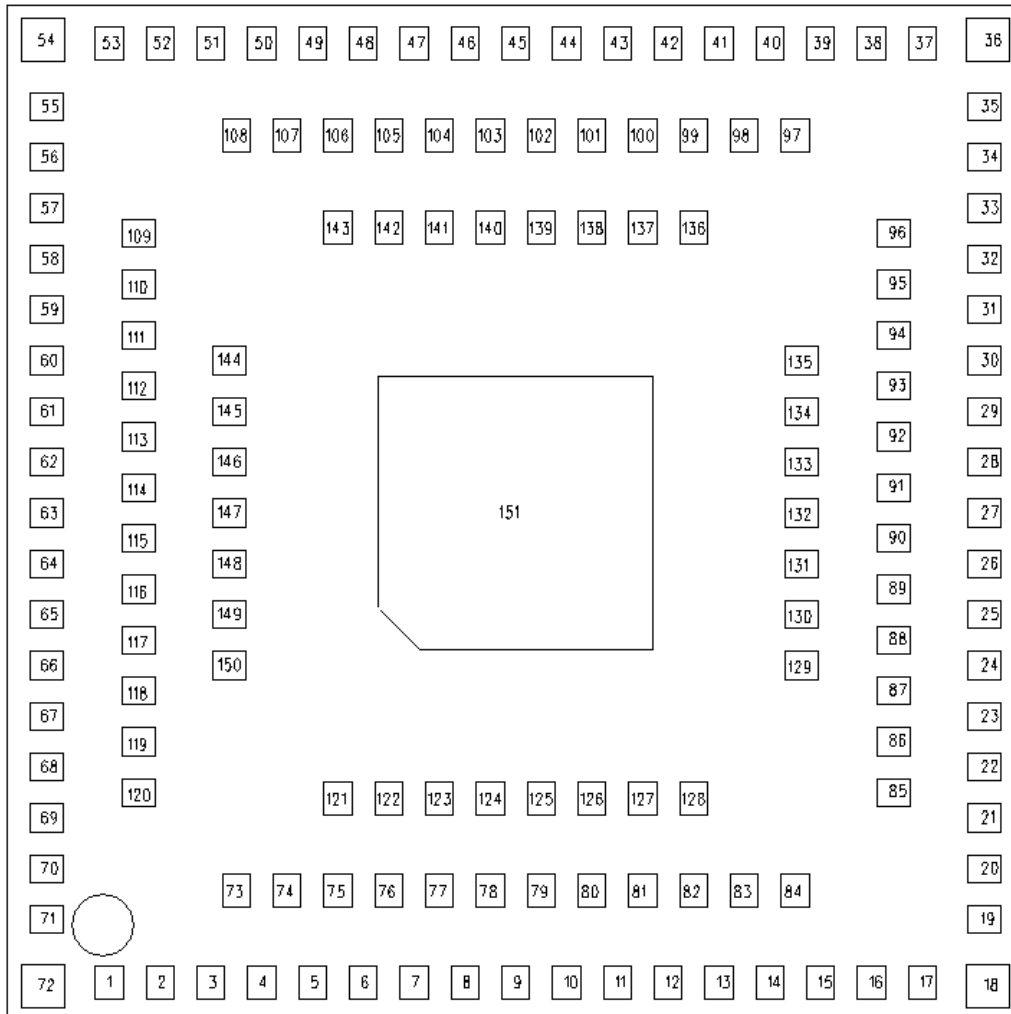

Figure 5: Sterling-EWB base SiP module pinout (top view)

6.2 Base SiP Module Pin Descriptions

Table 1: Sterling-EWB base SiP module pin descriptions

Module Pin	Name	I/O Type	Description	STM32F412 Port
1	ANT	RF	RF TRANSMITTER OUTPUT AND RECEIVE INPUT	
2	GND	GND	GROUND	
3	VDD_3V3_WIFI_PA	PI	WIFI PA POWER SUPPLY	
4	VDD_3V3_WIFI_PA	PI	WIFI PA POWER SUPPLY	
5	GND	GND	GROUND	
6	VDD_3V3_5	PI	DC SUPPLY FOR MCU AND I/O	
7	GND	GND	GROUND	
8	MICRO_SPI1_MOSI	DIO	SPI1_MOSI	PA7
9	QUADSPI_CLK	DIO	QUADSPI_CLK	PB1
10	GND	GND	GROUND	
11	MICRO_SPI4_NSS	DIO	SPI4_NSS	PE11
12	MICRO_SPI4_SCK	DIO	SPI4_SCK	PE12
13	MICRO_SPI4_MISO	DIO	SPI4_MISO	PE13
14	MICRO_SPI4_MOSI	DIO	SPI4_MOSI	PE14
15	GND	GND	GROUND	
16	NC	-	NO CONNECT (DO NOT CONNECT)	
17	NC	-	NO CONNECT (DO NOT CONNECT)	
18	GND	GND	GROUND	
19	NC	-	NO CONNECT (DO NOT CONNECT)	
20	BT_GPIO_3	DIO	WPT_INTb TO WIRELESS CHARGING PMU	
21	MICRO_SPI2_MISO	DIO	SPI4_MOSI	PB14
22	MICRO_SPI2_MOSI	DIO	SPI2_MOSI	PB15
23	GND	GND	GROUND	
24	VDD_3V3_3	PI	DC SUPPLY FOR MCU AND I/O	
25	GND	GND	GROUND	
26	NC	-	NO CONNECT (DO NOT CONNECT)	
27	GND	GND	GROUND	
28	VDD3V3_WiFi_IO	PI	DC SUPPLY FOR WIFI AND I/O	
29	GND	GND	GROUND	
30	MICRO_USART1_TX	DO	USART1_TX	PA9
31	MICRO_USART1_RX	DI	USART1_RX	PA10
32	MICRO_USART1_CTS	DI	USART1_CTS	PA11

Module Pin	Name	I/O Type	Description	STM32F412 Port
33	MICRO_USART1_RTS	DO	USART1_RTS	PA12
34	GND	GND	GROUND	
35	MICRO_JTAG_TMS	DI	JTAG_TMS	PA13
36	GND	GND	GROUND	
37	MICRO_JTAG_TCK	DI	JTAG_TCK	PA14
38	MICRO_JTAG_TDI	DI	JTAG_TDI	PA15
39	GND	GND	GROUND	
40	NC	-	NO CONNECT (DO NOT CONNECT)	
41	GND	GND	GROUND	
42	VDD3V3_WIFI	PI	WIFI POWER SUPPLY	
43	VDD3V3_WIFI	PI	WIFI POWER SUPPLY	
44	GND	GND	GROUND	
45	MICRO_JTAG_TDO	DO	JTAG_TDO	PB3
46	MICRO_JTAG_TRSTN	DI	JTAG_TRSTN	PB4
47	GND	GND	GROUND	
48	VDD_3V3_2	PI	DC SUPPLY FOR MCU AND I/O	
49	GND	GND	GROUND	
50	QUADSPI_BK1_IO3	DIO	QUADSPI_BK1_IO3	PF6
51	GND	GND	GROUND	
52	NC	-	NO CONNECT (DO NOT CONNECT)	
53	NC	-	NO CONNECT (DO NOT CONNECT)	
54	GND	GND	GROUND	
55	BT_PCM_CLK	DIO	PCM CLOCK; CAN BE MASTER (OUTPUT) OR SLAVE (INPUT)	
56	NC	-	NO CONNECT (DO NOT CONNECT)	
57	BT_HOST_WAKE	DO	HOST_WAKE	
58	GND	GND	GROUND	
59	VBAT	PI	POWER SUPPLY FOR BACKUP CIRCUIT	
60	GND	GND	GROUND	
61	GND	GND	GROUND	
62	NC	-	NO CONNECT (DO NOT CONNECT)	
63	NC	-	NO CONNECT (DO NOT CONNECT)	
64	GND	GND	GROUND	
65	VDD_3V3	PI	DC SUPPLY FOR MCU AND I/O	

Module Pin	Name	I/O Type	Description	STM32F412 Port
66	GND	GND	GROUND	
67	QUADSPI_BK1_IO1	DIO	QUADSPI_BK1_IO1	PF9
68	QUADSPI_BK1_IO2	DIO	QUADSPI_BK1_IO2	PF7
69	MICRO_I2S2_SD	DIO	I2S2_SD	PC3
70	GND	GND	GROUND	
71	GND	GND	GROUND	
72	GND	GND	GROUND	
73	GND	GND	GROUND	
74	MICRO_SPI1_NSS	DIO	SPI1_NSS	PA4
75	MICRO_SPI1_SCK	DIO	SPI1_SCK	PA5
76	MICRO_SPI1_MISO	DIO	SPI1_MISO	PA6
77	GND	GND	GROUND	
78	QUADSPI_BK2_IO3	DIO	QUADSPI_BK2_IO3	PC5
79	BOOT1/QUADSPI_CLK	DO	BOOT1/QUADSPI_CLK	PB2
80	QUADSPI_BK2_IO0	DIO	QUADSPI_BK2_IO0	PE7
81	QUADSPI_BK2_IO1	DIO	QUADSPI_BK2_IO1	PE8
82	MICRO_I2C2_SCL	DIO	I2C2_SCL	PB10
83	MICRO_I2C2_SDA	DIO	I2C2_SDA	PB11
84	MICRO_SPI2_NSS	DIO	SPI2_NSS	PB12
85	MICRO_SPI2_SCK	DIO	SPI2_SCK	PB13
86	MICRO_GPIO27	DIO	MICRO_GPIO	PD8
87	MICRO_GPIO25	DIO	MICRO_GPIO	PD10
88	NC	-	NO CONNECT (DO NOT CONNECT)	
89	NC	-	NO CONNECT (DO NOT CONNECT)	
90	VDD_USB	PI	DC SUPPLY FOR USB	
91	GND	GND	GROUND	
92	MICRO_I2S2_MCK/MICRO_USART6_TX	DIO	I2S2_MCK/USART6_TX	PC6
93	MICRO_I2S2_CK/MICRO_USART6_RX	DIO	I2S2_CK/USART6_RX	PC7
94	GND	GND	GROUND	
95	NC	-	NO CONNECT (DO NOT CONNECT)	
96	NC	-	NO CONNECT (DO NOT CONNECT)	
97	NC	-	NO CONNECT (DO NOT CONNECT)	
98	NC	-	NO CONNECT (DO NOT CONNECT)	
99	GND	GND	GROUND	

Module Pin	Name	I/O Type	Description	STM32F412 Port
100	NC	-	NO CONNECT (DO NOT CONNECT)	
101	GND	GND	GROUND	
102	MICRO_I2C1_SCL	DIO	I2C1_SCL	PB6
103	MICRO_I2C1_SDA	DIO	I2C1_SDA	PB7
104	BOOT0	DO	BOOT0	BOOT0
105	NC	-	NO CONNECT (DO NOT CONNECT)	
106	MICRO_GPIO0	DIO	MICRO_GPIO	PE3
107	QUADSPI_BK2_NCS	DIO	QUADSPI_BK2_NCS	PC11
108	MICRO_GPIO30	DIO	MICRO_GPIO	PE0
109	NC	-	NO CONNECT (DO NOT CONNECT)	
110	NC	-	NO CONNECT (DO NOT CONNECT)	
111	MICRO_I2S2_DI	DIO	I2S2_DI	PE5
112	GND	GND	GROUND	
113	GND	GND	GROUND	
114	GND	GND	GROUND	
115	GND	GND	GROUND	
116	GND	GND	GROUND	
117	MICRO_RST_N	DI	MICRO_RST_N	NRST
118	QUADSPI_BK1_IO0	DIO	QUADSPI_BK1_IO0	PF8
119	MICRO_WKUP	DI	MICRO_WKUP	PA0
120	GND	GND	GROUND	
121	MICRO_ADC_IN2	DI	ADC_IN2	PA2
122	MICRO_ADC_IN3	DI	ADC_IN3	PA3
123	GND	GND	GROUND	
124	QUADSPI_BK2_IO2	DIO	QUADSPI_BK2_IO2	PC4
125	MICRO_GPIO5	DIO	MICRO_GPIO	PB0
126	RF_SW_CTRL	DIO	ANTENNA DIVERSITY CONTROL	
127	NC	-	NO CONNECT (DO NOT CONNECT)	
128	MICRO_GPIO16	DIO	MICRO_GPIO	PE15
129	BT_GPIO_4	DIO	BSC_SDA TO/FROM WIRELESS CHARGING PMU	
130	BT_GPIO_5	DIO	BSC_SCL FROM WIRELESS CHARGING PMU.	
131	NC	-	NO CONNECT (DO NOT CONNECT)	
132	GND	GND	GROUND	
133	QUADSPI_BK1_NCS	DIO	QUADSPI_BK1_NCS	PG6

Module Pin	Name	I/O Type	Description	STM32F412 Port
134	GND	GND	GROUND	
135	GND	GND	GROUND	
136	NC	-	NO CONNECT (DO NOT CONNECT)	
137	MICRO_GPIO26	DIO	MICRO_GPIO	PD1
138	NC	-	NO CONNECT (DO NOT CONNECT)	
139	NC	-	NO CONNECT (DO NOT CONNECT)	
140	NC	-	NO CONNECT (DO NOT CONNECT)	
141	NC	-	NO CONNECT (DO NOT CONNECT)	
142	MICRO_GPIO28	DIO	MICRO_GPIO	PB8
143	MICRO_I2S2_WS	DIO	I2S2_WS	PB9
144	BT_PCM_SYNC	DIO	PCM SYNC; CAN BE MASTER (OUTPUT) OR SLAVE (INPUT)	
145	BT_PCM_OUT	DO	PCM DATA OUTPUT	
146	BT_PCM_IN	DI	PCM DATA INPUT SENSING	
147	PC13	DIO	MICRO_GPIO	PC13
148	GND	GND	GROUND	
149	GND	GND	GROUND	
150	MICRO_ADC_IN1	DI	ADC_IN1	PA1
151	GND	GND	GROUND	
PI = Power Input		DI = Digital Input		DO = Digital Output
DIO = Bi-directional Digital Port		RF = Bi-directional RF Port		GND = Ground

* If you want to use the USB interface, pins 30-33 (PA9-PA12) can be configured over USART1

7.2 U.FL/Chip Antenna Pin Description

Table 2: Sterling-EWB U.FL and Chip Antenna module pin descriptions

Module Pin	Name	I/O Type	Description
1	GND1	GND	GROUND
2	MICRO_ADC_IN2/PA2	DIO	ADC INPUT OR GENERAL-PURPOSE I/O
3	MICRO_SPI1_SCK/PA5	DIO	SPI SCK OR GENERAL-PURPOSE I/O
4	MICRO_SPI1_NSS/PA4	DIO	SPI NSS OR GENERAL-PURPOSE I/O
5	MICRO_SPI1_MISO/PA6	DIO	SPI MISO OR GENERAL-PURPOSE I/O
6	MICRO_ADC_IN3/PA3	DIO	ADC INPUT OR GENERAL-PURPOSE I/O
7	MICRO_GPIO_5/PB0	DIO	GENERAL-PURPOSE I/O
8	QUADSPI_BK2_IO2/PC4	DIO	QSPI IO2 OR GENERAL-PURPOSE I/O
9	VDD_WIFI_PA	PI	WIFI AND BLUETOOTH POWER SUPPLY
10	GND11	GND	GROUND
11	RF_SW_CNTL	DO	ANTENNA DIVERSITY CONTROL OUTPUT
12	QUADSPI_BK2_IO3/PC5	DIO	QSPI IO3 OR GENERAL-PURPOSE I/O
13	MICRO_SPI1_MOSI/PA7	DIO	SPI MOSI OR GENERAL-PURPOSE I/O
14	BOOT1/QUADSPI_CLK/PB2	DI	BOOT OPTION 1 INPUT
15	QUADSPI_CLK/PB1	DIO	QSPI CLK OR GENERAL-PURPOSE I/O
16	QUADSPI_BK2_IO0/PE7	DIO	QSPI IO0 OR GENERAL-PURPOSE I/O
17	MICRO_SPI4_NSS/PE11	DIO	SPI NSS OR GENERAL-PURPOSE I/O
18	QUADSPI_BK2_IO1/PE8	DIO	QSPI IO1 OR GENERAL-PURPOSE I/O
19	MICRO_SPI4_SCK/PE12	DIO	SPI SCK OR GENERAL-PURPOSE I/O
20	MICRO_I2C2_SCL/PB10	DIO	I2C SCL OR GENERAL-PURPOSE I/O
21	MICRO_SPI4_MISO/PE13	DIO	SPI MISO OR GENERAL-PURPOSE I/O
22	MICRO_I2C2_SDA/PB11	DIO	I2C SDA OR GENERAL-PURPOSE I/O
23	MICRO_SPI4_MOSI/PE14	DIO	SPI MOSI OR GENERAL-PURPOSE I/O
24	MICRO_GPIO_16/PE15	DIO	GENERAL-PURPOSE I/O
25	BT_GPIO_3	DIO	BT GENERAL-PURPOSE I/O
26	MICRO_SPI2_NSS/PB12	DIO	SPI NSS OR GENERAL-PURPOSE I/O
27	MICRO_SPI2_SCK/PB13	DIO	SPI SCK OR GENERAL-PURPOSE I/O
28	MICRO_SPI2_MISO/PB14	DIO	SPI MISO OR GENERAL-PURPOSE I/O
29	GND2	GND	GROUND
30	MICRO_SPI2_MOSI/PB15	DIO	SPI MOSI OR GENERAL-PURPOSE I/O
31	MICRO_GPIO_27/PD8	DIO	GENERAL-PURPOSE I/O

Module Pin	Name	I/O Type	Description
32	MICRO_GPIO_25/PD10	DIO	GENERAL-PURPOSE I/O
33	BT_GPIO_4	DIO	BT GENERAL-PURPOSE I/O
34	BT_GPIO_5	DIO	BT GENERAL-PURPOSE I/O
35	VDD_USB	PI	VUSB POWER SUPPLY
36	QUADSPI_BK1_NCS/PG6	DIO	QSPI NCS OR GENERAL-PURPOSE I/O
37	VDD_MCU	PI	MCU AND IO POWER SUPPLY
38	MICRO_I2S2_CK/MICRO_USART6_RX/PC7	DIO	I2S CK OR USART RX INPUT OR GENERAL-PURPOSE I/O
39	MICRO_I2S2_MCK/MICRO_USART6_TX/PC6	DIO	I2S MCK OR USART TX OUTPUT OR GENERAL-PURPOSE I/O
40	GND12	GND	GROUND
41	VDD_WIFI_IO	PI	WIFI AND BLUETOOTH IO POWER SUPPLY
42	MICRO_USART1_RX/PA10	DI	MCU USART1 RECEIVE INPUT
43	MICRO_USART1_TX/PA9	DO	MCU USART1 TRANSMIT OUTPUT
44	MICRO_GPIO_26/PD1	DIO	GENERAL-PURPOSE I/O
45	MICRO_GPIO_28/PB8	DIO	GENERAL-PURPOSE I/O
46	MICRO_I2C1_SDA/PB7	DIO	I2C SDA OR GENERAL-PURPOSE I/O
47	MICRO_USART1_CTS/PA11	DI	MCU USART1 CLEAR-TO-SEND
48	MICRO_I2C1_SCL/PB6	DIO	I2C SCL OR GENERAL-PURPOSE I/O
49	MICRO_USART1_RTS/PA12	DO	MCU USART1 REQUEST-TO-SEND
50	MICRO_JTAG_TDI	DI	JTAG_TDI
51	MICRO_JTAG_TMS/SWDIO	DI	JTAG_TMS/SWDIO
52	GND3	GND	GROUND
53	BOOT0	DI	BOOT OPTION 0 INPUT
54	MICRO_JTAG_TDO	DI	JTAG_TDO
55	PC13	DIO	GENERAL-PURPOSE I/O
56	MICRO_ADC_IN1/PA1	DIO	ADC INPUT OR GPIO
57	MICRO_JTAG_TCK/SWCLK	DI	JTAG_TCK/SWCLK
58	BT_PCM_IN	DI	PCM DATA INPUT SENSING
59	BT_PCM_OUT	DO	PCM DATA OUTPUT
60	MICRO_RSTN	DI	MCU RESET INPUT
61	BT_PCM_SYNC	DIO	PCM SYNC; CAN BE MASTER (OUTPUT) OR SLAVE (INPUT)
62	VDD_WIFI	PI	WIFI AND BLUETOOTH POWER SUPPLY
63	GND4	GND	GROUND

Module Pin	Name	I/O Type	Description
64	MICRO_JTAG_TRSTN	DI	JTAG_TRSTN
65	MICRO_GPIO_0/PE3	DIO	GENERAL-PURPOSE I/O
66	QUADSPI_BK1_IO0/PF8	DIO	QSPI IO0 OR GENERAL-PURPOSE I/O
67	QUADSPI_BK2_NCS/PC11	DIO	QSPI NCS OR GENERAL-PURPOSE I/O
68	QUADSPI_BK1_IO1/PF9	DIO	QSPI IO1 OR GENERAL-PURPOSE I/O
69	MICRO_I2S2_WS/PB9	DIO	I2S WS OR GENERAL-PURPOSE I/O
70	QUADSPI_BK1_IO3/PF6	DIO	QSPI IO3 OR GENERAL-PURPOSE I/O
71	MICRO_GPIO_30/PE0	DIO	GENERAL-PURPOSE I/O
72	OSC_32K_IN	DI	EXTERNAL SLEEP CLOCK INPUT (not used)
73	MICRO_I2S_DI/PE5	DIO	I2S DATA INPUT OR GENERAL-PURPOSE I/O
74	OSC_32K_OUT	DO	EXTERNAL SLEEP CLOCK INPUT (not used)
75	BT_PCM_CLK	DIO	PCM CLOCK; CAN BE MASTER (OUTPUT) OR SLAVE (INPUT)
76	MICRO_WKUP/PA0	DI	MCU WAKE INPUT
77	BT_HOST_WAKE	DO	HOST_WAKE OR GENERAL-PURPOSE I/O
78	QUADSPI_BK1_IO2/PF7	DIO	QSPI IO2 OR GENERAL-PURPOSE I/O
79	MICRO_I2S2_SD/PC3	DIO	I2S DATA OUTPUT OR GENERAL-PURPOSE I/O
80	VBAT	PI	WIFI AND BLUETOOTH POWER SUPPLY
81	GND5	GND	GROUND
82	GND6	GND	GROUND
83	GND7	GND	GROUND
84	GND8	GND	GROUND
85	GND9	GND	GROUND
86	GND10	GND	GROUND
87	GND13	GND	GROUND

PI = Power Input	DI = Digital Input	DO = Digital Output
DIO = Bi-directional Digital Port	GND = Ground	

8 SPECIFICATIONS

8.1 General Characteristics

Characteristic	Description
Model Name	Sterling-EWB
Product Description	Wi-Fi and Bluetooth wireless module with Cortex™-M4 MCU
SiP Module Dimensions (W x L x T) – mm (in.)	10 x 10 x 1.2 (0.39 x 0.39 x 0.05)
Antenna Option Module Dimensions (W x L x T) – mm (in.)	16 x 21 x 2.8 (0.63 x 0.83 x 0.11)
Operating Temperature – °C (°F)	-40 to +85 (-40 to +185)
Storage Temperature – °C (°F)	-40 to +125 (-40 to +257)
Weight	0.0015167KGS

8.2 Power Supply Requirements

Power Supply Input	Min	Typical	Max	Unit
VDD_MCU	2.4	3.3	3.6	V
VDD_WIFI	3.0	3.3	3.6	V
VDD_WIFI_IO	3.0	3.3	3.6	V
VDD_WIFI_PA	3.0	3.3	3.6	V
VDD_USB ⁽¹⁾	3.0	3.3	3.6	V
VBAT ⁽²⁾	2.4	3.3	3.6	V

(1) If USB not used, connect VDD_USB input to VDD_MCU

(2) If VBAT not used, connect to VDD_MCU

8.2.1 RF Characteristics

Parameter	Min	Typical	Max	Unit
RF frequency range	2400		2500	MHz
RF data rate	1	802.11 b/g/n rates supported	65	Mbps

8.3 Maximum Ratings

Rating	Value	Unit
VDD_MCU	0 to 4	V
VDD_WIFI	0 to 6	V
VDD_WIFI_IO	0 to 4	V
VDD_WIFI_PA	0 to 6	V
VDD_USB	0 to 4	V
VBAT	0 to 4	V
Voltage ripple any supply input (not to exceed operating voltage)	±2%	Not to exceed operating voltage
Output current sunk by any I/O or control pin	25	mA
Output current sourced by any I/O or control pin	-25	mA
Total output current sunk by sum of all I/O or control pin	120	mA
Total output current sourced by sum of all I/O or control pin	-120	mA

8.4 WLAN Power Consumption

Parameter	Test Conditions	Min	Typical	Max	Unit
11b TX Current	11 Mbps, T _{amb} = +25°C, 3.3V	-	390	-	mA
11g TX Current	54 Mbps, T _{amb} = +25°C, 3.3V	-	310	-	mA
11n TX Current	MCS7, T _{amb} = +25°C, 3.3V	-	290	-	mA
11b RX Current	11 Mbps, T _{amb} = +25°C, 3.3V	-	55	-	mA
11g RX Current	54 Mbps, T _{amb} = +25°C, 3.3V	-	55	-	mA
11n RX Current	MCS7, T _{amb} = +25°C, 3.3V	-	55	-	mA

8.5 Bluetooth Power Consumption

Parameter	Test Conditions	Min	Typical	Max	Unit
EDR TX Current	Constant Transmit, 3DH5, PRBS9 T _{amb} = +25°C, 3.3V	-	50	-	mA
EDR RX Current	Constant Receive, 3DH5 T _{amb} = +25°C, 3.3V	-	30	-	mA
BLE TX Current	T _{amb} = +25°C, 3.3V	-	50	-	mA
BLE RX Current	T _{amb} = +25°C, 3.3V	-	30	-	mA

8.6 WLAN RF Characteristics

8.6.1 WLAN Transmitter Characteristics (TA = +25°C, VCC = 3.3 V)

Parameter	Test Conditions	Min	Typ	Max	Unit
1 Mbps DSSS (b) TX Output Power	1 Mbps BPSK 802.11(b) Mask Compliance 35% EVM RMS power over TX packet	-	17.5	-	dBm
2 Mbps DSSS (b) TX Output Power	2 Mbps QPSK 802.11(b) Mask Compliance 35% EVM RMS power over TX packet	-	17.5	-	dBm
5.5 Mbps DSSS (b) TX Output Power	5.5 Mbps QPSK 802.11(b) Mask Compliance 35% EVM RMS power over TX packet	-	17.5	-	dBm
11 Mbps DSSS (b) TX Output Power	11 Mbps CCK 802.11(b) Mask Compliance 35% EVM RMS power over TX packet	-	17.5	-	dBm
6 Mbps OFDM (g) TX Output Power	6 Mbps BPSK 802.11(g) Mask Compliance -5 dB EVM RMS power over TX packet	-	14.0	-	dBm
9 Mbps OFDM (g) TX Output Power	9 Mbps BPSK 802.11(g) Mask Compliance -8 dB EVM RMS power over TX packet	-	14.0	-	dBm
12 Mbps OFDM (g) TX Output Power	12 Mbps QPSK 802.11(g) Mask Compliance -10 dB EVM RMS power over TX packet	-	14.0	-	dBm
18 Mbps OFDM (g) TX Output Power	18 Mbps QPSK 802.11(g) Mask Compliance -13 dB EVM RMS power over TX packet	-	14.0	-	dBm
24 Mbps OFDM (g) TX Output Power	24 Mbps 16-QAM 802.11(g) Mask Compliance -16 dB EVM RMS power over TX packet	-	14.0	-	dBm
36 Mbps OFDM (g) TX Output Power	36 Mbps 16-QAM 802.11(g) Mask Compliance -19 dB EVM RMS power over TX packet	-	14.0	-	dBm
48 Mbps OFDM (g) TX Output Power	48 Mbps 64-QAM 802.11(g) Mask Compliance -22 dB EVM RMS power over TX packet	-	14.0	-	dBm
54 Mbps OFDM (g) TX Output Power	54 Mbps 64-QAM 802.11(g) Mask Compliance -25 dB EVM RMS power over TX packet	-	14.0	-	dBm
MCS0 OFDM (n) TX Output Power	6.5 Mbps BPSK 802.11(n) Mask Compliance -5 dB EVM RMS power over TX packet	-	12.5	-	dBm
MCS1 OFDM (n) TX Output Power	13 Mbps QPSK 802.11(n) Mask Compliance -10 dB EVM RMS power over TX packet	-	12.5	-	dBm
MCS2 OFDM (n) TX Output Power	19.5 Mbps QPSK 802.11(n) Mask Compliance -13 dB EVM RMS power over TX packet	-	12.5	-	dBm
MCS3 OFDM (n) TX Output Power	26 Mbps 16-QAM 802.11(n) Mask Compliance -16 dB EVM RMS power over TX packet	-	12.5	-	dBm
MCS4 OFDM (n) TX Output Power	39 Mbps 16-QAM 802.11(n) Mask Compliance -19 dB EVM RMS power over TX packet	-	12.5	-	dBm

Parameter	Test Conditions	Min	Typ	Max	Unit
MCS5 OFDM (n) TX Output Power	52 Mbps 64-QAM 802.11(n) Mask Compliance -22 dB EVM RMS power over TX packet	-	12.5	-	dBm
MCS6 OFDM (n) TX Output Power	58.5 Mbps 64-QAM 802.11(n) Mask Compliance -25 dB EVM RMS power over TX packet	-	12.5	-	dBm
MCS7 OFDM (n) TX Output Power	65 Mbps 64-QAM 802.11(n) Mask Compliance -27 dB EVM RMS power over TX packet	-	12.5	-	dBm

8.6.2 WLAN Receiver Characteristics (TA = +25°C, VCC = 3.3 V)

Parameter	Test Conditions	Min	Typ	Max	Unit
1 Mbps DSSS (b) RX Sensitivity	8% PER	-	-93	-	dBm
2 Mbps DSSS (b) RX Sensitivity	8% PER	-	-91	-	dBm
5.5 Mbps DSSS (b) RX Sensitivity	8% PER	-	-89	-	dBm
11 Mbps DSSS (b) RX Sensitivity	8% PER	-	-86	-	dBm
6 Mbps OFDM (g) RX Sensitivity	10% PER	-	-88	-	dBm
9 Mbps OFDM (g) RX Sensitivity	10% PER	-	-87	-	dBm
12 Mbps OFDM (g) RX Sensitivity	10% PER	-	-85	-	dBm
18 Mbps OFDM (g) RX Sensitivity	10% PER	-	-83	-	dBm
24 Mbps OFDM (g) RX Sensitivity	10% PER	-	-80	-	dBm
36 Mbps OFDM (g) RX Sensitivity	10% PER	-	-78	-	dBm
48 Mbps OFDM (g) RX Sensitivity	10% PER	-	-74	-	dBm
54 Mbps OFDM (g) RX Sensitivity	10% PER	-	-72	-	dBm
MCS0 (6.5 Mbps) OFDM (n) RX Sensitivity	10% PER	-	-87	-	dBm
MCS1 (13 Mbps) OFDM (n) RX Sensitivity	10% PER	-	-84	-	dBm
MCS2 (19.5 Mbps) OFDM (n) RX Sensitivity	10% PER	-	-82	-	dBm
MCS3 26 Mbps OFDM (n) RX Sensitivity	10% PER	-	-80	-	dBm
MCS4 39 Mbps OFDM (n) RX Sensitivity	10% PER	-	-77	-	dBm
MCS5 52 Mbps OFDM (n) RX Sensitivity	10% PER	-	-72	-	dBm
MCS6 58.5 Mbps OFDM (n) RX Sensitivity	10% PER	-	-71	-	dBm
MCS7 65 Mbps OFDM (n) RX Sensitivity	10% PER	-	-70	-	dBm

Parameter	Test Conditions	Min	Typ	Max	Unit
11b RX Overload Level	8% PER, 11 Mbps	-10	-	-	dBm
11g RX Overload Level	10% PER, 54 Mbps	-20	-	-	dBm
11n RX Overload Level	10% PER, MCS7	-20	-	-	dBm

8.7 Bluetooth RF Characteristics

8.7.1 Bluetooth Transmitter GFSK & EDR Characteristics (TA=25°C, VDD=3.3 V)

Parameter	Test Conditions	Min	Typical	Max	Bluetooth Spec	Unit
GFSK RF Output Power		-	8.5	-		dBm
EDR RF Output Power		-	4.0	-		dBm
Power Control Step Size		2	4	8	2-8	dB
EDR Relative Power		-4		1	-4/+1	dB

8.7.2 Bluetooth Receiver GFSK & EDR Characteristics (TA=25°C, VDD=3.3 V)

Table 3: Bluetooth receiver RF characteristics

Parameter	Test Conditions	Min	Typical	Max	Bluetooth Spec	Unit
GFSK Sensitivity	BER=0.1%	-	-90	-	-70	dBm
EDR 2 Mbps Sensitivity	BER=0.01%	-	-92	-	-70	dBm
EDR 3 Mbps Sensitivity	BER=0.01%	-	-87	-	-70	dBm
GFSK Maximum Input Level	BER=0.1%	-	-20	-	-20	dBm
EDR 2 Maximum Input Level	BER=0.01%	-	-20	-	-	dBm
EDR 3 Maximum Input Level	BER=0.01%	-	-20	-	-	dBm

8.7.3 BLE Transmitter Characteristics (TA=25°C, VDD=3.3 V)

Table 4: BLE transmitter RF characteristics

Parameter	Test Conditions	Min	Typical	Max	Bluetooth Spec	Unit
GFSK RF Output Power		-	7.5	-		dBm
Power Control Step Size		2	4	8	2-8	dB

8.7.4 BLE Receiver Characteristics (TA=25°C, VDD=3.3 V)

Table 5: BLE receiver RF characteristics

Parameter	Test Conditions	Min	Typical	Max	Bluetooth Spec	Unit
GFSK Sensitivity	PER = 30.8%	-	-94	-	-70	dBm
GMSK Maximum Input Level	PER = 30.8%	-	-20	-	-20	dBm

9 MCU INTERFACE CHARACTERISTICS

9.1 DC Characteristics – General Input and Output

Table 6: DC characteristics MCU I/O

Parameter	Test Conditions	Min	Max	Unit
Logic input low, V _{IL}	2.4V ≤ VDD_MCU ≤ 3.6V	-	0.3V _{DD}	V
Logic input high, V _{IH}	2.4V ≤ VDD_MCU ≤ 3.6V	0.7V _{DD}	-	V
BOOT0 Logic input low, V _{IL}	2.4V ≤ VDD_MCU ≤ 3.6V	-	0.1V _{DD} + 0.1	V
BOOT0 Logic input high, V _{IH}	2.4V ≤ VDD_MCU ≤ 3.6V	0.17V _{DD} + 0.7	-	V
Logic output low, V _{OL}	2.7V ≤ VDD_MCU ≤ 3.6V CMOS port, I _{IO} = +8mA	-	0.4	V
	2.7V ≤ VDD_MCU ≤ 3.6V TTL port, I _{IO} = +8mA	-	0.4	
	2.7V ≤ VDD_MCU ≤ 3.6V I _{IO} = +20mA	-	1.3	
	2.4V ≤ VDD_MCU ≤ 3.6V I _{IO} = +6mA	-	0.4	
	2.4V ≤ VDD_MCU ≤ 3.6V I _{IO} = +4mA	-	0.4	
Logic output high, V _{OH}	2.7V ≤ VDD_MCU ≤ 3.6V CMOS port, I _{IO} = +8mA	V _{DD} - 0.4	-	V
	2.7V ≤ VDD_MCU ≤ 3.6V TTL port, I _{IO} = +8mA	2.4	-	
	2.7V ≤ VDD_MCU ≤ 3.6V I _{IO} = +20mA	V _{DD} - 1.3	-	
	2.4V ≤ VDD_MCU ≤ 3.6V I _{IO} = +6mA	V _{DD} - 0.4	-	
	2.4V ≤ VDD_MCU ≤ 3.6V I _{IO} = +4mA	V _{DD} - 0.4	-	

TTL and CMOS outputs are compatible with JEDEC standards JESD36 and JESD52

9.2 I2C Interface

9.2.1 Overview

The Sterling-EWB Module MCU section supports Standard and Fast mode I2C communication.

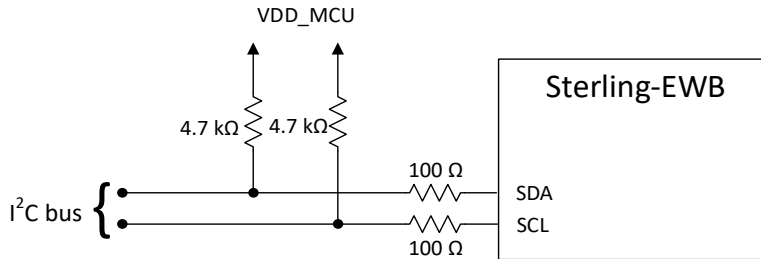
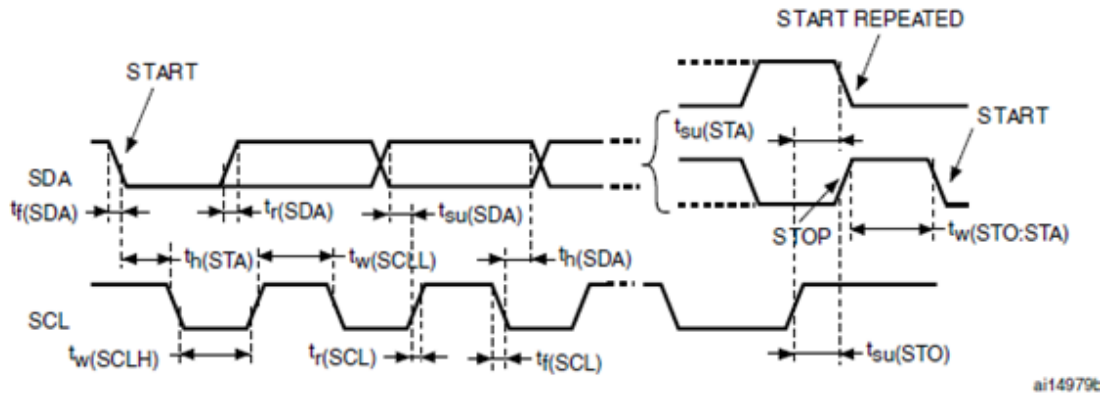

Table 7: Signal connections to I2C bus

Symbol	Parameter	Standard Mode ⁽¹⁾		Fast Mode ⁽¹⁾⁽²⁾		Unit
		Min	Max	Min	Max	
$t_{w(SCLL)}$	SCL clock low time	4.7	-	1.3	-	μs
$t_{w(SCLH)}$	SCL clock high time	4.0	-	0.6	-	μs
$t_{su(SDA)}$	SDA setup time	250	-	100	-	ns
$t_h(SDA)$	SDA data hold time	0	3450 ⁽³⁾	0	900 ⁽⁴⁾	ns
$t_r(SDA)$ $t_r(SCL)$	SDA and SCL rise time	-	1000	-	300	ns
$t_f(SDA)$ $t_f(SCL)$	SDA and SCL fall time	-	300	-	300	ns
$t_h(SDA)$	Start condition hold time	4.0	-	0.6	-	μs
$t_{su(STA)}$	Repeated Start condition setup time	4.7	-	0.6	-	μs
$t_{su(STO)}$	Stop condition setup time	4.0	-	0.6	-	μs
$t_{sw(STO:STA)}$	Stop to Start condition time (bus free)	4.7	-	1.3	-	μs
t_{SP}	Pulse width of the spikes that are suppressed by the analog filter for standard fast mode	0	50	0	50	μs
C_b	Capacitive load for each bus line	-	400	-	400	pF

1. Guaranteed by design, not tested in production.
2. f_{PCLK1} must be at least 2 MHz to achieve standard mode I2C frequencies. It must be at least 4MHz to achieve fast mode I2C frequencies, and a multiple of 10MHz to reach the 400 kHz maximum I2C fast mode clock.
3. The device must internally provide a hold time of at least 300ns for the SDA signal in order to bridge the undefined region of the falling edge of SCL.

4. The maximum data hold time has only to be met if the interface does not stretch the low period of SCL signal.



Measurement points are done at 0.3V_{DD} and 0.7V_{DD}

9.3 SPI Interface

Table 8: SPI interface characteristics

Parameter	Test Conditions	Min	Typical	Max	Unit
SPI Clock Frequency	Master full duplex/receiver mode 2.7V < VDD_MCU < 3.6V SPI1/4/5	-	-	42	MHz
	Master full duplex/receiver mode 3.0V < VDD_MCU < 3.6V SPI1/4/5	-	-	50	
	Master transmitter mode 2.4V < VDD_MCU < 3.6V SPI1/4/5	-	-	50	
	Master mode 2.4V < VDD_MCU < 3.6V SPI1/2/3/4/5	-	-	25	
	Slave transmitter/full duplex mode 2.7V < VDD_MCU < 3.6V SPI1/4/5	-	-	38 ⁽¹⁾	
	Slave receiver mode 2.4V < VDD_MCU < 3.6V SPI1/4/5	-	-	50	
	Slave mode 2.4V < VDD_MCU < 3.6V SPI1/2/3/4/5	-	-	25	
Duty cycle of SPI Clock	Slave mode	30	50	70	%
SCK high and low time	Master mode, SPI presc = 2	T _{PCLK} - 1.5	T _{PCLK}	T _{PCLK} - 1.5	ns
NSS setup time	Slave mode, SPI presc = 2	3T _{PCLK}	-	-	ns
NSS hold time	Slave mode, SPI presc = 2	2T _{PCLK}	-	-	ns
Data input setup time	Master mode	4	-	-	ns
	Slave mode	2.5	-	-	ns
Data input hold time	Master mode	7.5	-	-	ns
	Slave mode	3.5	-	-	ns

10 MCU UART INTERFACES

10.1 Overview

The Sterling-EWB is configurable for up to three UART interfaces for serial communications. The UART is a standard 4-wire interface (RX, TX, RTS, and CTS) with adjustable baud rates from 9600 bps to 4.0 Mbps. The interface features an automatic baud rate detection capability that returns a baud rate selection. The baud rate may also be selected through a vendor-specific UART HCI command.

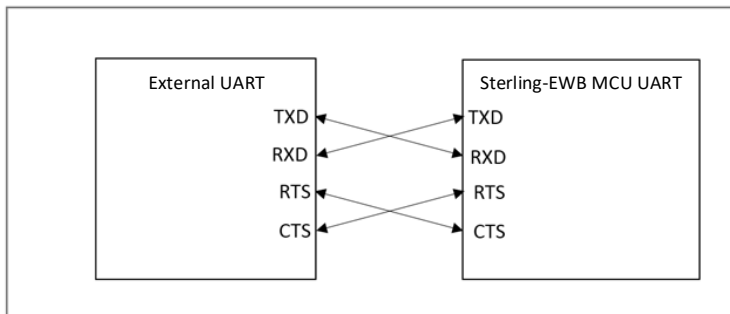

Figure 7: UART connection between Sterling-EWB and external device

10.2 Soldering Recommendations

10.2.1 Reflow for Lead Free Solder Paste

- Optimal solder reflow profile depends on solder paste properties and should be optimized as part of an overall process development.
- It is important to provide a solder reflow profile that matches the solder paste supplier's recommendations.
- Temperature ranges beyond that of the solder paste supplier's recommendation could result in poor solderability.
- All solder paste suppliers recommend an ideal reflow profile to give the best solderability.

10.3 Recommended Reflow Profile for Lead Free Solder

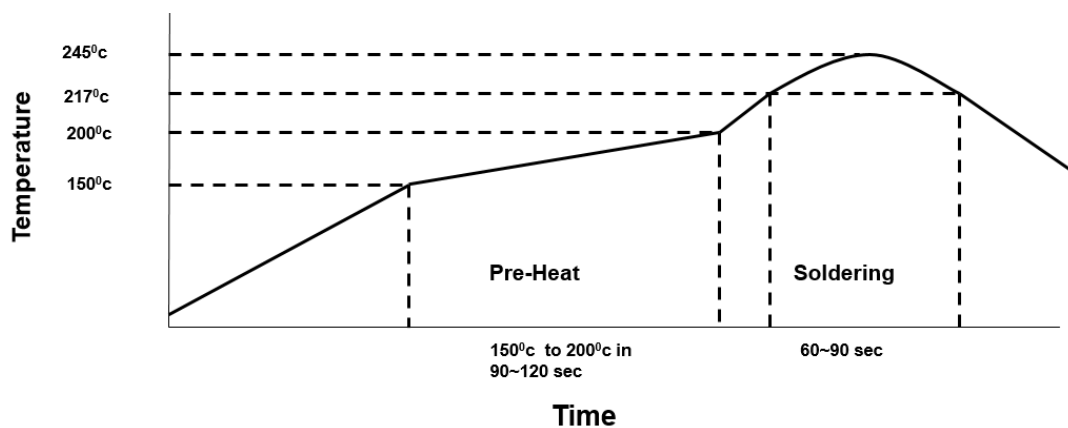

Figure 8: Recommended soldering profile

Note: The quality of solder joints on the surface mount pads where they contact the host board should meet the appropriate IPC Specification. See *IPC-A-610-D Acceptability of Electronic Assemblies*, section 8.2.1 *Bottom Only Terminations*.

11 Wi-Fi MAC IDs/BLUETOOTH MAC IDs

Table 9: Example of MAC ID assignments

	Wi-Fi MAC ID	Bluetooth MAC ID
Module 1	C0:EE:40:07:00:01	C0:EE:40:07:00:02
Module 2	C0:EE:40:07:00:03	C0:EE:40:07:00:04
Module 3	C0:EE:40:07:00:05	C0:EE:40:07:00:06
Module 4	C0:EE:40:07:00:07	C0:EE:40:07:00:08

12 MECHANICAL DETAILS

12.1 Base SiP Module Mechanical Data

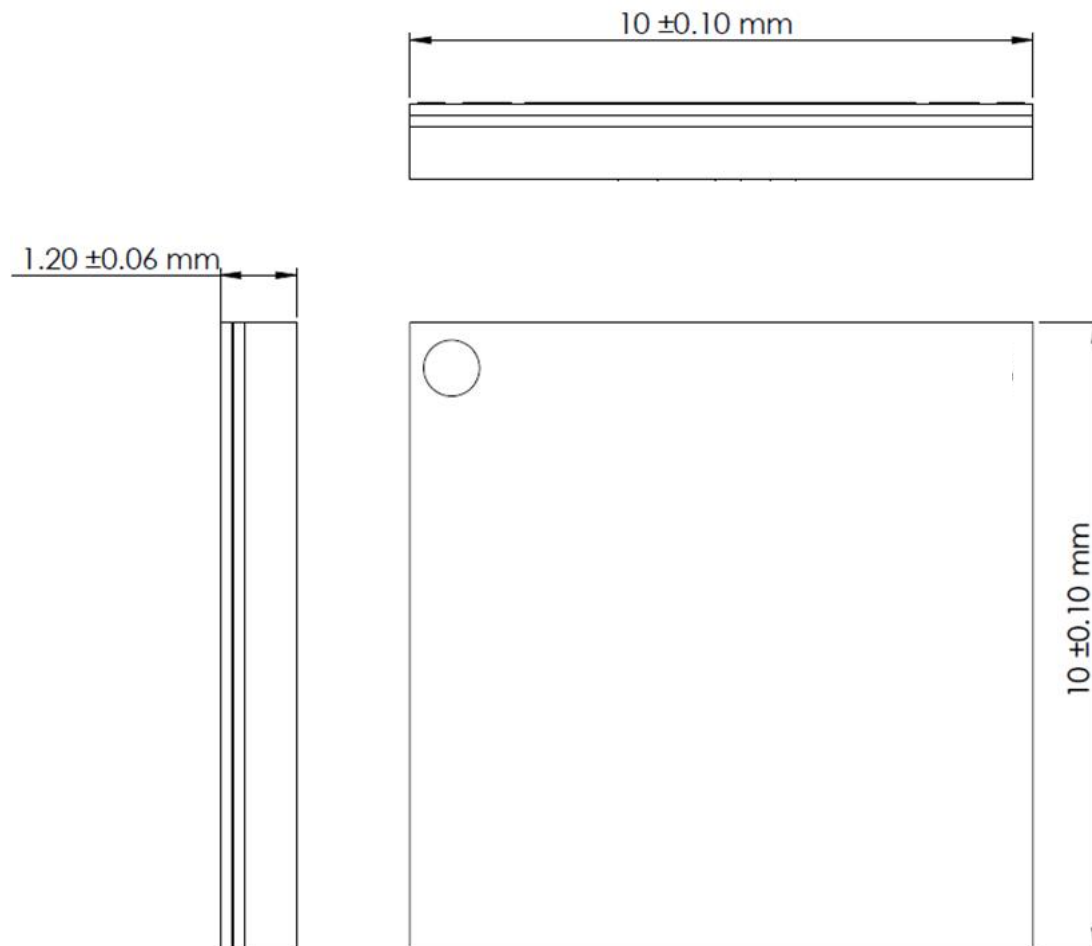

Figure 9: Base SiP module mechanical dimensions

12.3 Base SiP Module Recommended Solder Stencil

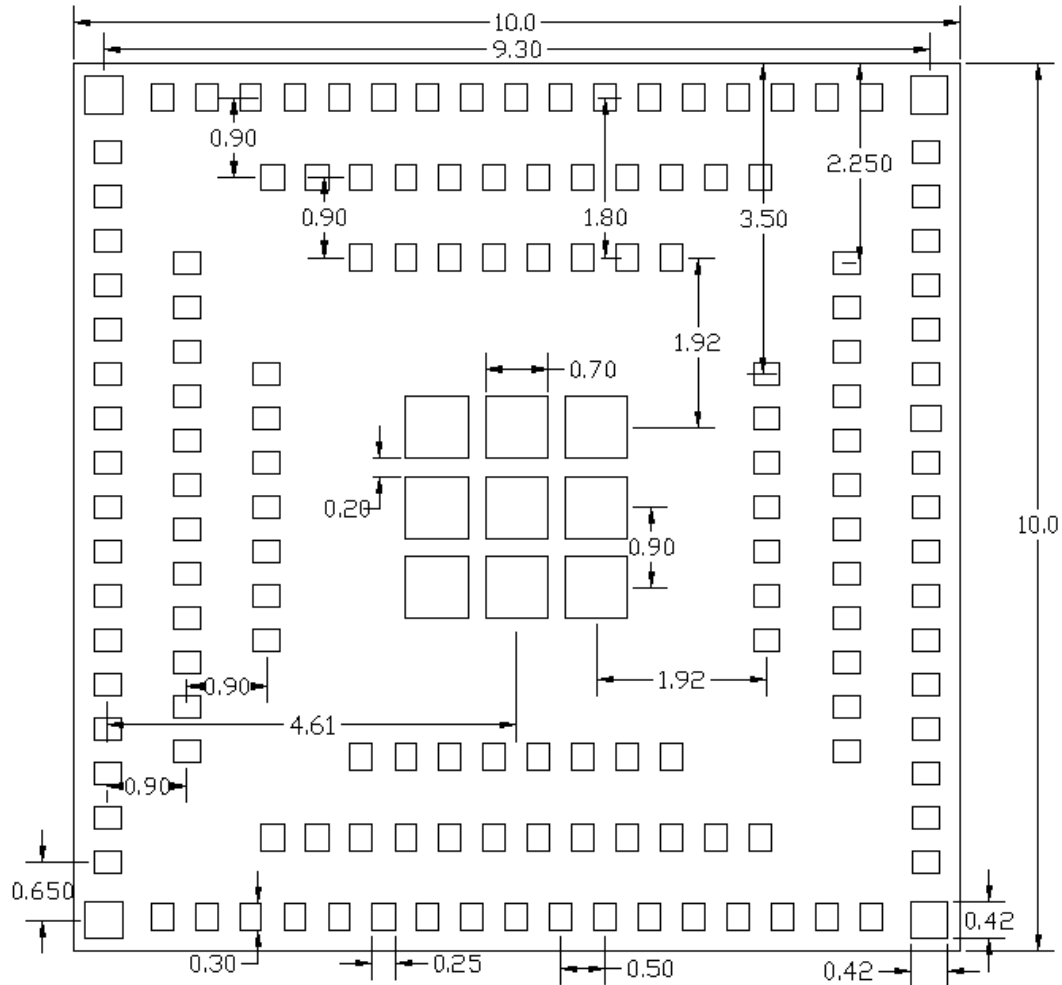

Figure 11: Base SiP module recommended solder stencil (top view)

Note: Solder mask and paste mask to be adjusted according to end-user's assembly process.

12.4 Base SiP Module Tape and Reel Packaging

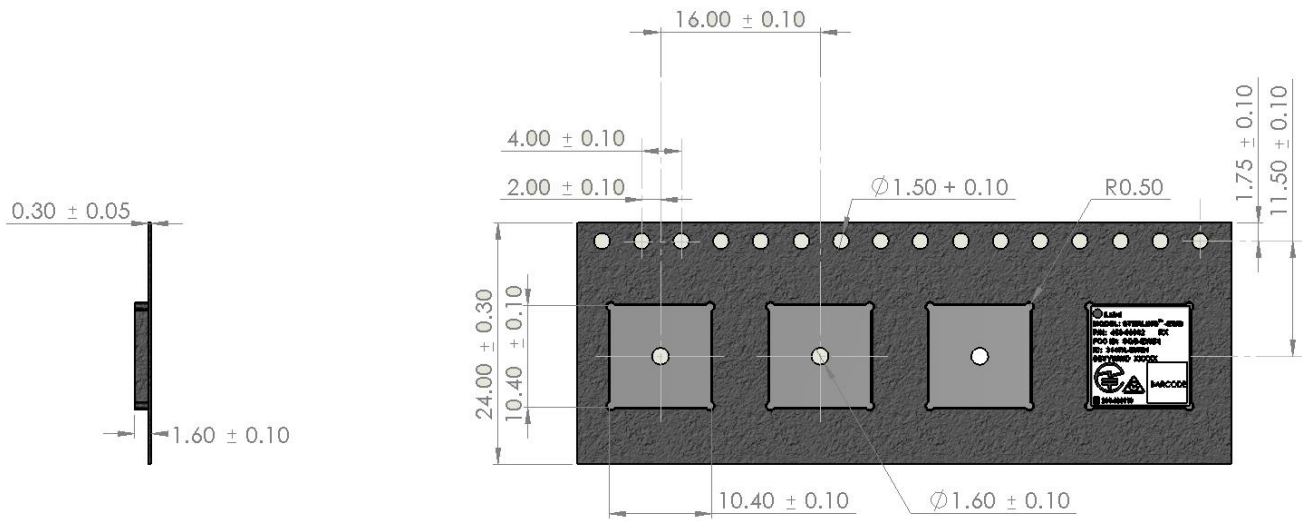

Figure 12: Base SiP module tape and reel specification

Notes:

- 1) DIM in mm
- 2) 10 sprocket hole pitch cumulative tolerance ± 0.10 mm
- 3) Pocket position relative to sprocket hole measured as true position of pocket, not pocket hole
- 4) Full reel contains 2000 modules

The module must be in this orientation when feeding the tape.

12.6 U.FL and Chip Antenna Tape and Reel Packaging

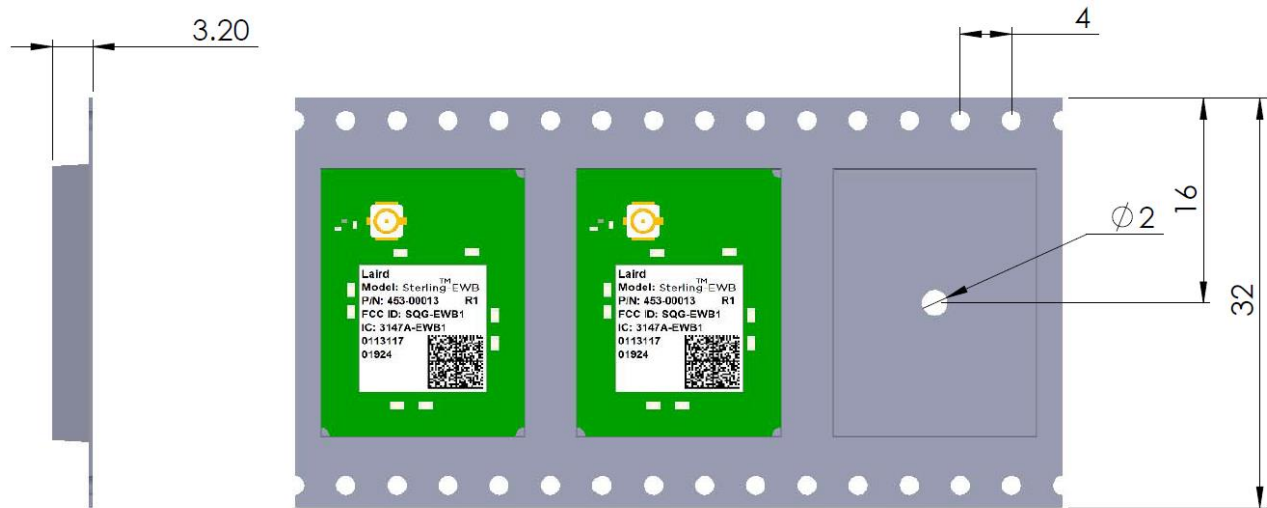
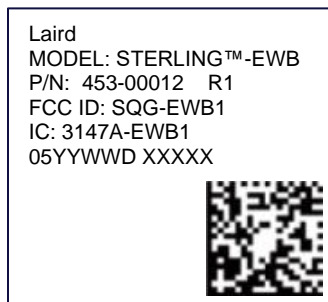

Figure 14: U.FL and chip antenna modules tape and reel specification (full reel contains 1000 modules)

12.7 Device Markings

12.7.1 SiP Module

The shield on the 453-00012 base module contains the following information:



12.7.2 Antenna Option Modules

The shield on the 453-00013 and 453-00014 modules contains the following information:



13 CLEANING

In general, cleaning the populated modules is strongly discouraged. Residuals under the module cannot be easily removed with any cleaning process.

- Cleaning with water can lead to capillary effects where water is absorbed into the gap between the host board and the module. The combination of soldering flux residuals and encapsulated water could lead to short circuits between neighboring pads. Water could also damage any stickers or labels.
- Cleaning with alcohol or a similar organic solvent will likely flood soldering flux residuals into the RF shield, which is not accessible for post-washing inspection. The solvent could also damage any stickers or labels.
- Ultrasonic cleaning could damage the module permanently.

14 OPTICAL INSPECTION

After soldering the module to the host board, consider optical inspection to check the following:

- Proper alignment and centering of the module over the pads.
- Proper solder joints on all pads.
- Excessive solder or contacts to neighboring pads, or vias.

15 REWORK

The Sterling-EWB module can be unsoldered from the host board if the Moisture Sensitivity Level (MSL) requirements are met as described in this datasheet.

Note: Never attempt a rework on the module itself, e.g. replacing individual components. Such actions will terminate warranty coverage.

16 SHIPPING, HANDLING, AND STORAGE

16.1 Shipping

Bulk orders of the Sterling-EWB base module are delivered in reels of 2000. Bulk orders for the antenna option PCBAs are delivered in reels of 1000.

16.2 Handling

The Sterling-EWB modules contain a highly sensitive electronic circuitry. Handling without proper ESD protection may damage the module permanently.

16.3 Moisture Sensitivity Level (MSL)

Per J-STD-020, devices rated as MSL 4 and not stored in a sealed bag with desiccant pack should be baked prior to use.

Devices are packaged in a Moisture Barrier Bag with a desiccant pack and Humidity Indicator Card (HIC). Devices that will be subjected to reflow should reference the HIC and J-STD-033 to determine if baking is required.

If baking is required, refer to J-STD-033 for bake procedure.

16.4 Storage

Per J-STD-033, the shelf life of devices in a Moisture Barrier Bag is 12 months at <40C and <90% room humidity (RH).

Do not store in salty air or in an environment with a high concentration of corrosive gas, such as Cl₂, H₂S, NH₃, SO₂, or NO_x.

Do not store in direct sunlight.

The product should not be subject to excessive mechanical shock.

16.5 Repeated Reflow Soldering

Only a single reflow soldering process is encouraged for host boards.

17 REGULATORY

17.1 FCC and IC Regulatory – Pending

This equipment has been tested and found to comply with the limits for a Class B digital device, pursuant to Part 15 of the FCC Rules. These limits are designed to provide reasonable protection against harmful interference in a residential installation. This equipment generates, uses and can radiate radio frequency energy and, if not installed and used in accordance with the instructions, may cause harmful interference to radio communications. However, there is no guarantee that interference will not occur in a particular installation. If this equipment does cause harmful interference to radio or television reception, which can be determined by turning the equipment off and on, the user is encouraged to try to correct the interference by one of the following measures:

- Reorient or relocate the receiving antenna.
- Increase the separation between the equipment and receiver.
- Connect the equipment into an outlet on a circuit different from that to which the receiver is connected.
- Consult the dealer or an experienced radio/TV technician for help.

FCC Caution: Any changes or modifications not expressly approved by the party responsible for compliance could void the user's authority to operate this equipment.

This device complies with Part 15 of the FCC Rules. Operation is subject to the following two conditions: (1) This device may not cause harmful interference, and (2) this device must accept any interference received, including interference that may cause undesired operation.

IMPORTANT NOTE:

FCC Radiation Exposure Statement:

This equipment complies with FCC radiation exposure limits set forth for an uncontrolled environment. This equipment should be installed and operated with minimum distance 20 cm between the radiator and your body.

This transmitter must not be co-located or operating in conjunction with any other antenna or transmitter.

Integration instructions for Host Product Manufacturers

Applicable FCC Rules to Module

FCC Part 15.247

Summarize the specific operational use conditions

The module must be installed in mobile devices.

This device is intended for OEM integrators under the following conditions:

- The antenna must be installed such that 20 centimeters is maintained between the antenna and users, and
- The transmitter module may not be co-located with any other transmitter or antenna

As long as the two conditions above are met, further transmitter testing is not required. However, the OEM integrator is still responsible for testing their end-product for any additional compliance requirements with this module installed.

IMPORTANT NOTE: In the event that these conditions cannot be met (for example certain laptop configurations or co-location with another transmitter), then the FCC authorization is no longer considered valid and the FCC ID cannot be used on the final product. In these circumstances, the OEM integrator will be responsible for re-evaluating the end product (including the transmitter) and obtaining a separate FCC authorization. The OEM integrator has to be aware not to provide information to the end user regarding how to install or remove this RF module in the user's manual of the end product which integrates this module.

The end user manual shall include all required regulatory information/warnings as shown in this manual.

Limited Module Procedures

Not applicable

Trace Antenna Designs

Not applicable

RF Exposure Considerations

20-centimeter separation distance and co-located issue shall be met at mentioned in *Summarize the specific operational use conditions.*

The product manufacturer shall provide the text below in the end-product manual:

This equipment complies with FCC radiation exposure limits set forth for an uncontrolled environment. This equipment should be installed and operated with a minimum distance of 20 centimeters between the radiator and your body.

Antennas

Brand Name	Model Name	Antenna Type	Antenna Gain	Antenna Connector
ACX	AT3216-A2R4PAA	Chip	1.5	N/A
Laird	001-0001	Dipole	2.0	R-SMA
Laird	001-0014	FlexPIFA	2.0	U.FL
Laird	001-0015	FlexNotch	2.0	U.FL
Laird	001-0030	mFlexPIFA	2.0	U.FL
Laird	NanoBlue	PCB Dipole	2.0	U.FL

Label and Compliance Information

Product manufacturers must provide with the finished product a physical or electronic label stating the following:

Contains FCC ID: SQG-EWB1

Information on Test Modes and Additional Testing Requirements

Test tool: The Cypress WICED SDK shall be used to set the module to transmit continuously.

Additional Testing – Part 15 Subpart B Disclaimer

The module is only FCC authorized for the specific rule parts listed on the grant, and that the host product manufacturer is responsible for compliance to any other FCC rules that apply to the host not covered by the modular transmitter grant of certification. The final host product still requires Part 15 Subpart B compliance testing with the modular transmitter installed.

Industry Canada Statement

This device contains licence-exempt transmitter(s)/receiver(s) that comply with Innovation, Science and Economic Development Canada's licence-exempt RSS(s). Operation is subject to the following two conditions:

- (1) This device may not cause interference*
- (2) This device must accept any interference, including interference that may cause undesired operation of the device*

Cet appareil contient des émetteurs / récepteurs exempts de licence qui sont conformes au (x) RSS (s) exemptés de licence d'Innovation, Sciences et Développement économique Canada. L'opération est soumise aux deux conditions suivantes:

- (1) Cet appareil ne doit pas causer d'interférences*
- (2) Cet appareil doit accepter toute interférence, y compris les interférences pouvant provoquer un fonctionnement indésirable de l'appareil*

This radio transmitter (IC: 3147A-EWB1) has been approved by Industry Canada to operate with the antenna types listed below with the maximum permissible gain indicated. Antenna types not included in this list, having a gain greater than the maximum gain indicated for that type, are strictly prohibited for use with this device.

Le présent émetteur radio (IC: 3147A-EWB1) a été approuvé par Industrie Canada pour fonctionner avec les types d'antenne énumérés ci-dessous et ayant un gain admissible maximal. Les types d'antenne non inclus dans cette liste, et dont le gain est supérieur au gain maximal indiqué, sont strictement interdits pour l'exploitation de l'émetteur.

Brand Name	Model Name	Antenna Type	Antenna Gain	Antenna Connector
ACX	AT3216-A2R4PAA	Chip	1.5	N/A
Laird	001-0001	Dipole	2.0	R-SMA
Laird	001-0014	FlexPIFA	2.0	U.FL

Brand Name	Model Name	Antenna Type	Antenna Gain	Antenna Connector
Laird	001-0015	FlexNotch	2.0	U.FL
Laird	001-0030	PIFA	2.0	U.FL
Laird	NanoBlue/ EBL2400A1-10MH4L	PCB Dipole	2.0	U.FL

Caution:

(i) the device for operation in the band 5150–5250 MHz is only for indoor use to reduce the potential for harmful interference to co-channel mobile satellite systems;

(ii) for devices with detachable antenna(s), the maximum antenna gain permitted for devices in the bands 5250-5350 MHz and 5470-5725 MHz shall be such that the equipment still complies with the e.i.r.p. limit;

(iii) for devices with detachable antenna(s), the maximum antenna gain permitted for devices in the band 5725-5850 MHz shall be such that the equipment still complies with the e.i.r.p. limits specified for point-to-point and non-point-to-point operation as appropriate; and

Operations in the 5.25-5.35GHz band are restricted to indoor usage only.

Avertissement:

(i) les dispositifs fonctionnant dans la bande de 5150 à 5250MHz sont réservés uniquement pour une utilisation à l'intérieur afin de réduire les risques de brouillage préjudiciable aux systèmes de satellites mobiles utilisant les mêmes canaux;

(ii) pour les dispositifs munis d'antennes amovibles, le gain maximal d'antenne permis pour les dispositifs utilisant les bandes de 5250 à 5350MHz et de 5470 à 5725 MHz doit être conforme à la limite de la p.i.r.e.;

(iii) pour les dispositifs munis d'antennes amovibles, le gain maximal d'antenne permis (pour les dispositifs utilisant la bande de 5725 à 5850 MHz) doit être conforme à la limite de la p.i.r.e. spécifiée pour l'exploitation point à point et l'exploitation non point à point, selon le cas;

Les opérations dans la bande de 5.25-5.35GHz sont limités à un usage intérieur seulement.

Radiation Exposure Statement:

This equipment complies with Canada radiation exposure limits set forth for an uncontrolled environment. This equipment should be installed and operated with minimum distance 20cm between the radiator & your body.

Déclaration d'exposition aux radiations:

Cet équipement est conforme Canada limites d'exposition aux radiations dans un environnement non contrôlé. Cet équipement doit être installé et utilisé à distance minimum de 20cm entre le radiateur et votre corps.

This device is intended only for OEM integrators under the following condition:

1) The transmitter module may not be co-located with any other transmitter or antenna.

As long as the condition above is met, further transmitter testing is not required. However, the OEM integrator is still responsible for testing their end-product for any additional compliance requirements required with this module installed.

Cet appareil est conçu uniquement pour les intégrateurs OEM dans les conditions suivantes:

1) Le module émetteur peut ne pas être coïmplanté avec un autre émetteur ou antenne.

Tant que les 1 condition ci-dessus sont remplies, des essais supplémentaires sur l'émetteur ne seront pas nécessaires. Toutefois, l'intégrateur OEM est toujours responsable des essais sur son produit final pour toutes exigences de conformité supplémentaires requis pour ce module installé.

IMPORTANT NOTE:

In the event that these conditions can not be met (for example certain laptop configurations or co-location with another transmitter), then the Canada authorization is no longer considered valid and the IC ID can not be used on the final product. In these circumstances, the OEM integrator will be responsible for re-evaluating the end product (including the transmitter) and obtaining a separate Canada authorization.

NOTE IMPORTANTE:

Dans le cas où ces conditions ne peuvent être satisfaites (par exemple pour certaines configurations d'ordinateur portable ou de certaines co-localisation avec un autre émetteur), l'autorisation du Canada n'est plus considéré comme valide et l'ID IC ne peut pas être utilisé sur le produit final. Dans ces circonstances, l'intégrateur OEM sera chargé de réévaluer le produit final (y compris l'émetteur) et l'obtention d'une autorisation distincte au Canada.

End Product Labeling

The final end product must be labeled in a visible area with the following: *Contains IC: 3147A-SU60SOMC.*

Plaque signalétique du produit final

Le produit final doit être étiqueté dans un endroit visible avec l'inscription suivante: *Contient des IC: 3147A-SU60SOMC.*

Manual Information to the End User

The OEM integrator has to be aware not to provide information to the end user regarding how to install or remove this RF module in the user's manual of the end product which integrates this module.

The end user manual shall include all required regulatory information/warning as show in this manual.

Manuel d'information à l'utilisateur final

L'intégrateur OEM doit être conscient de ne pas fournir des informations à l'utilisateur final quant à la façon d'installer ou de supprimer ce module RF dans le manuel de l'utilisateur du produit final qui intègre ce module.

Le manuel de l'utilisateur final doit inclure toutes les informations réglementaires requises et avertissements comme indiqué dans ce manuel.

17.2 Europe – EU Declaration of Conformity

This device complies with the essential requirements of the Radio Equipment directive: 2014 / 53 / EU. The following test methods have been applied in order to prove presumption of conformity with the essential requirements of the Radio Equipment directive: **2014 / 53 / EU**:

- EN 300 328 V2.1.1
- EN 301 893 V2.1.1
- Draft EN 301 489-1 V2.2.0
- Draft EN 301 489-17 V3.2.0
- EN 50385:2017
- EN 62311:2008
- EN 60950-1: 2006+A11:2009+A1:2010+A12:2011+A2:2013

2400~2480 MHz: 17 dBm
SW version: v1.0

The minimum distance between the user and/or any bystander and the radiating structure of the transmitter is 20cm.

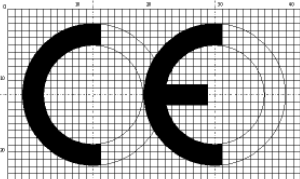

17.3 Japan (MIC) Regulatory

Pending Giteki: CAB ID-Certification Number

17.4 Australia and New Zealand

RCM: Pending Compliant to standards EN 300 328 V1.9.1, AS/NZS 4268: 2012-A1:2013, and EN 55022:2010/AC:2011

If this device is used in a product, the OEM has responsibility to verify compliance of the final end product to the Australia/New Zealand (RCM) Standards. All end-products require their own certification (SDoc). You will not be able to leverage the module certification and ship product into the country.

18 BLUETOOTH SIG QUALIFICATION

18.1 Overview

The Sterling-EWB module is listed on the Bluetooth SIG website as a qualified Controller Subsystem.

Table 10: Sterling-EWB declaration ID

Design Name	Owner	Declaration ID	Link to listing on the SIG website
	Laird		
	Laird		
	Laird		

It is a mandatory requirement of the Bluetooth Special Interest Group (SIG) that every product implementing Bluetooth technology has a Declaration ID. Every Bluetooth design is required to go through the qualification process, even when referencing a Bluetooth Design that already has its own Declaration ID. The Qualification

Process requires each company to register as a member of the Bluetooth SIG – www.bluetooth.org

The following is a link to the Bluetooth Registration page: <https://www.bluetooth.org/login/register/>

For each Bluetooth Design it is necessary to purchase a Declaration ID. This can be done before starting the new qualification, either through invoicing or credit card payment. The fees for the Declaration ID will depend on your membership status, please refer to the following webpage:

<https://www.bluetooth.org/en-us/test-qualification/qualification-overview/fees>

For a detailed procedure of how to obtain a new Declaration ID for your design, please refer to the following SIG document, (login is required to view this document):

https://www.bluetooth.org/DocMan/handlers/DownloadDoc.ashx?doc_id=283698&vId=317486

18.2 Qualification Steps When Referencing a Laird Controller Subsystem Design

To qualify your product when referencing a Laird Controller Subsystem design, follow these steps:

1. To start a listing, go to: https://www.bluetooth.org/tpg/QLI_SDoc.cfm

Note: A user name and password are required to access this site.

2. In step 1, select the option, New Listing and Reference a Qualified Design.
3. Enter xxxxx in the Controller Subsystem table entry.
4. Enter your complimentary Host Subsystem and optional Profile Subsystem in the table entry.
5. Select your pre-paid Declaration ID from the drop-down menu or go to the Purchase Declaration ID page.

Note: Unless the Declaration ID is pre-paid or purchased with a credit card, you cannot proceed until the SIG invoice is paid.

6. Once all the relevant sections of step 1 are finished, complete steps 2, 3, and 4 as described in the help document accessible from the site.

Your new design will be listed on the SIG website and you can print your Certificate and SDoC.

For further information please refer to the following training material:

<https://www.bluetooth.org/en-us/test-qualification/qualification-overview/listing-process-updates>

18.3 Additional Assistance

Please contact your local sales representative or our support team for further assistance:

Email support@lairdconnect.com

Phone Americas: +1-800-492-2320
Europe: +44-1628-858-940
Hong Kong: +852 2923 0610

Web <https://www.lairdconnect.com/wireless-modules>