

User Guide

Sterling-EWB Development Kit - Hardware

Part # 455-00030 and 455-00031

Version 1.2

REVISION HISTORY

Version	Date	Notes	Contributor(s)	Approver
1.0	17 July 2019	Initial version	Dave Neperud	Jay White
1.1	06 Aug 2019	Fixed typo in EWB development Kit power supply diagram (Figure 4)	Dave Neperud	Jay White
1.2	18 Sept 2020	Fixed module part reference in DVK parts list	Dave Drogowski	Jay White
1.3	11 Mar 2020	Added reference to the AT command software	Bob Monroe	Jonathan Kaye

CONTENTS

1	Overview	4
2	Laird Sterling-EWB Development Kit Part Numbers	4
3	Package Contents	4
4	Development Kit – Main Development Board	4
4.1	Key Features	4
5	Understanding the Development Board	5
5.1	EWB-DVK Default Configuration and Jumper Settings	6
6	Functional Blocks	7
6.1	Power Supply	7
6.2	Module Reset Button	8
6.3	USB Programming and Debug Interface	8
6.4	Boot Option Configuration Switches	8
6.5	DVK Disconnect Switches	8
6.6	UART Interfaces	9
6.7	Indicator LEDs	9
6.8	Push Buttons	9
6.9	MCU Wake Button	10
6.10	BME680 Gas/Pressure/Temperature/Humidity Sensor	10
6.11	External Host Interface	10
7	Breakout Connector Pinouts	12
7.1	Trace debugging (JTAG) Interface	12
7.2	Bluetooth Interface	12
7.2.1	Bluetooth PCM Audio Interface	12
7.2.2	Bluetooth GPIO Interface	12
7.2.3	Bluetooth Wake Interface	12
7.3	PIN Breakout Headers	13
8	Other Features	14
8.1	Current Consumption Measurements	14
9	APPENDIX A – EWB Module Pin to MCU Port Mapping	15
10	APPENDIX B – EWB/STM32F412 Alternative Functions	17
11	Additional Documentation	18

1 OVERVIEW

The Laird Sterling-EWB development kit provides a platform for development of embedded Wi-Fi and/or Bluetooth Low Energy (BLE) applications. This document describes the development board hardware, highlighting the setup and interfaces available to maximize user flexibility in developing these applications.

2 LAIRD STERLING-EWB DEVELOPMENT KIT PART NUMBERS

Part Number	Product Description
455-00030	Development Kit for 453-00014 module – Integrated chip antenna
455-00031	Development Kit for the 453-00013 module – w/ u.FL antenna connector

Applicable to the following Sterling-EWB module part numbers:

Part Number	Product Description
453-00014	Sterling-EWB chip antenna module – Integrated antenna
453-00013	Sterling-EWB U.FL module – External antenna

Note: For information about the AT Command software, please reference the [AT Command Set Guide](#). The AT Command software can be programmed and utilized on any of the above part numbers.

3 PACKAGE CONTENTS

All kits contain the following items:

Development Board	The development board has the required Sterling-EWB module soldered onto it and exposes all available hardware interfaces.
USB Cable	USB cable – Type A to micro type B. The cable also provides serial communications via the FTDI USB – RS232 converter chip on the board and powers the development board.
External 2.4GHz dipole antenna	Supplied with development kit part # 455-00031 only. External antenna, 2 dBi, FlexPIFA (Laird part #001-0014) with integral RF coaxial cable with 100 mm length and IPEX-4 compatible RF connector.

4 DEVELOPMENT KIT – MAIN DEVELOPMENT BOARD

The Sterling-EWB development board is designed to be used directly with the Cypress WICED® SDK. The default configurations provided in this document will enable operation and software development on this board.

4.1 Key Features

The EWB development board has the following features:

- Sterling-EWB series module soldered onto the development board
- The following power supply options for powering the development board:
 - USB (micro-USB, type B)
 - External DC supply (4.4 – 10V) – not supplied. Center positive barrel connector or header for bench supply.
 - (4) AA batteries (not supplied)
- Powering the EWB module using a single on-board regulator or separating the MCU and radio supplies to use individual on-board regulators (SW8)
- USB to UART/JTAG bridge (FTDI chip)
- Pin headers for measuring current (EWB module only)
- Selectable boot options

- IO break-out 2.54 mm pitch pin header connectors that bring out all MCU interfaces of the EWB module – UART, SPI, QSPI, I2C, SIO [DIO or AIN (ADCs)], I2S, PWM – and allow for plugging in external modules/sensors
- IO breakout 2.54 mm pitch pin header for direct access to Bluetooth radio on the EWB module.
- DIP switches on all EWB module IO lines running to peripheral devices on the development board to allow disconnection.
- J-Link JTAG header for access to EWB JTAG
- 2.54 mm pitch pin header connector and level-shifter supporting connection to an external host MCU (1.8V - 5.0V logic levels).
- On-board Bosch Sensortec BME680 environmental sensor
- Two buttons and four LEDs for user interaction
- One Reset button
- One Wake button
- Optional footprint for Apple MFI co-processor (not populated)
- Optional footprint for Microchip ATECC608A-SSHDA authentication IC (not populated)

5 UNDERSTANDING THE DEVELOPMENT BOARD

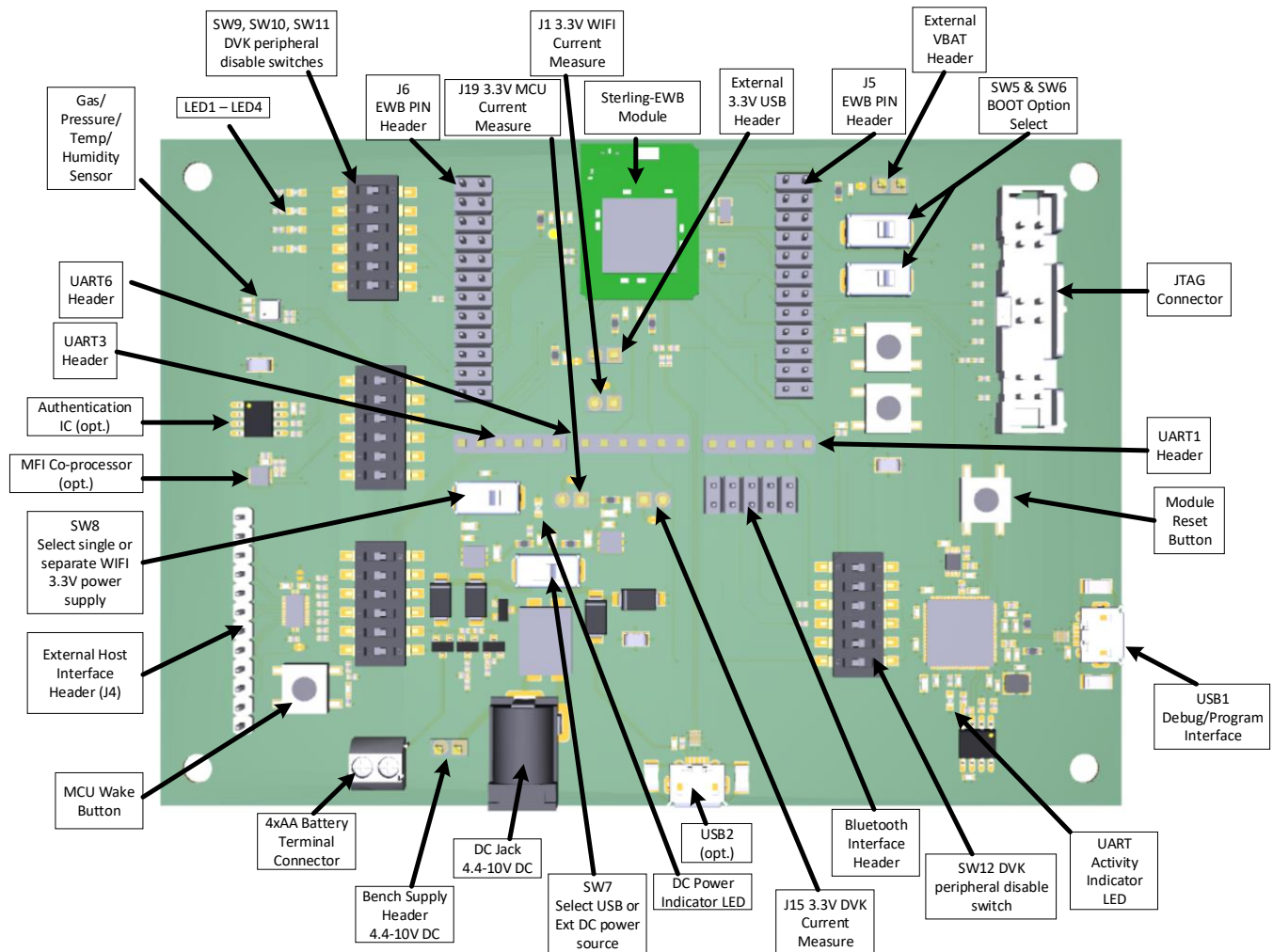

Figure 1: Development board contents and locations



Figure 2: Development board 455-00030 (fitted with 453-00014 EWB module with integrated chip antenna)

5.1 EWB-DVK Default Configuration and Jumper Settings

IMPORTANT! To ensure correct out-of-the-box configuration, the EWB development board switches must be configured as shown in Figure 3.

The default power connection is using the provided USB cable plugged into the DEBUG/PROGRAM micro-USB port.

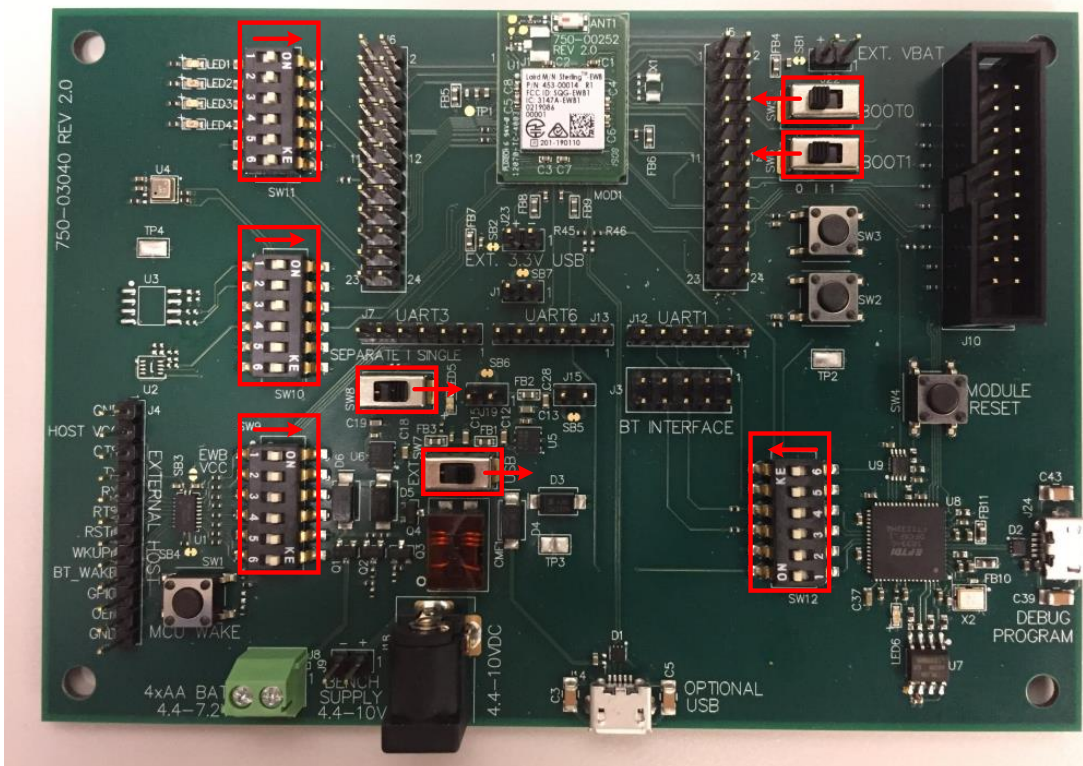

Figure 3: Correct EWB development board 455-00030 or 455-00031 switch settings (image for 455-00030)

6 FUNCTIONAL BLOCKS

6.1 Power Supply

Figure 4 shows the EWB development board power supply tree.

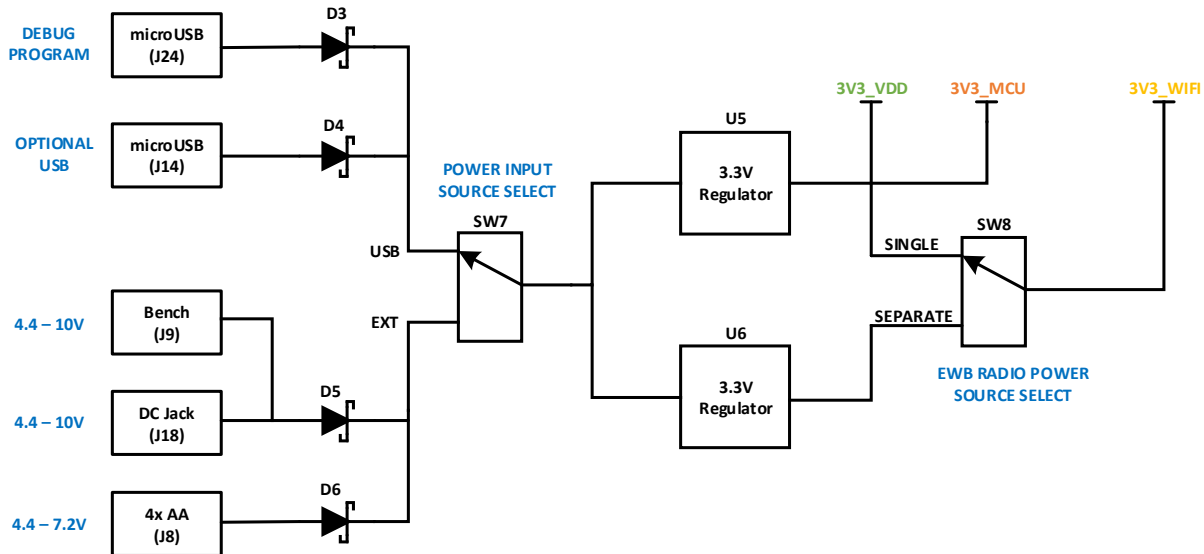

Figure 4: EWB development Kit power supply

There are five options for powering the development board:

- DEBUG/PROGRAM USB port (micro-B connector) – If using the FTDI USB-UART path (Default)
- OPTIONAL USB port (micro-B connector) – USB function is not supported/connected on the EWB module, but port can be used as a power input
- External DC supply (4.4V-10V), into DC jack connector (J18)
- External DC bench supply (4.4V-10V) using 2-pin header (J9)
- AA batteries – Four AA batteries connected to terminal block (J8)

The external power sources are fed into selection switch SW7 which allows the selection between either USB sources or the external DC sources.

The external power source is regulated to a fixed 3.3V on the development board. Two regulators are on the development board to provide the option to power the EWB module from a single supply or to separate the supplies for the EWB MCU (3V3_MCU) and radio (3V3_WIFI) sections. The development board peripherals are also powered by U5 (3V3_VDD).

The EWB module power supply inputs are sourced as following on the development board:

3V3_WIFI

- VDD_WIFI_PA (pin 9)
- VDD_WIFI_IO (pin 41)
- VDD_WIFI (pin 62)

3V3_MCU

- VDD_MCU (pin 37)
- VDD_USB (pin 35)
- VBAT (pin 80)

Note: The EWB module currently does not support the external USB interface, so the VDD_USB pin is tied directly to 3V3_MCU. The VDD_USB pin supplies power to GPIO PA11 and PA12 on the EWB module.

Note: The development board connects the VBAT pin directly to 3V3_MCU. An external battery voltage can be applied to the EWB module by cutting SB1 to remove the connection to 3V3_MCU and applying a battery voltage to J22 (Figure 5).

The VBAT pin powers the battery power (RTC and backup registers) domain only when VDD is not present.



Figure 5: External VBAT power connector

6.2 Module Reset Button

The development board Module Reset button (SW4) connects directly to the EWB MICRO_RSTN pin and enables manual reset of the module MCU when pressed.

6.3 USB Programming and Debug Interface

The micro-USB connector J24 is used in conjunction with a FTDI FT2232H multipurpose USB UART/FIFO IC on the development board to provide JTAG programming and UART1 serial port access to the STM32F412 MCU on the EWB module.

The FT2232H has an external EEPROM which is pre-programmed with the custom VID (0x0A5C) and PID (0x43FA) to enable the USB port to interface with the Cypress WICED® software development kit as well as provide a COM port for monitoring the debug output of the Laird Sterling-EWB demo application.

6.4 Boot Option Configuration Switches

The EWB development board boot option is configured by setting SW5 and SW6 (Figure 6).

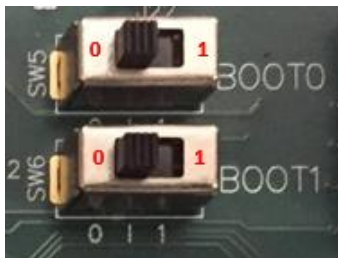

Figure 6: BOOT configuration switches

Table 1: EWB boot source configuration

SW5 (BOOT 0) position	SW6 (BOOT 1) position	Boot Source
0	0 or 1	EWB Module boots from embedded User Flash (Default Setting)
1	1	EWB Module boots from Embedded SRAM
1	0	EWB Module boots from System Memory

6.5 DVK Disconnect Switches

The development board contains SPST DIP switches (SW9 – SW12) placed in-line with the EWB module I/O lines that connect to peripheral devices on the board. This functionality is provided to maximize flexibility, allowing the user to disconnect any EWB module I/O used by the development board, re-assign their functionality, and use them for development purposes.

6.6 UART Interfaces

The EWB module is configurable for up to three UART interfaces which can be accessed through headers J7, J12, and J13 on the development board.

Four-wire UART interfaces (TX, RX, CTS, RTS) are available on J12 (UART1) and J7 (UART3). J13 (UART6) only provides a 2-wire interface (TX, RX).

Note: UART1 is also driven by the FTDI FT2232H multipurpose USB UART IC to provide a terminal COM port connection available at the micro-USB port (J24). To enable use of a direct external UART connection at J12, SW12 positions 1 – 4 must be switched to the OFF position.

The UART connections to the EWB module are shown in [Table 2](#).

Table 2: EWB pin/UART connections available on development board

UART1 (J12)	UART1 (J12)	UART3 (J7)	UART6 (J13)
UART_TX (output)	PA9	PD8	PC6
UART_RX (input)	PA10	PC5	PC7
UART_RTS (output)	PA12	PB14	N/A
UART_CTS (input)	PA11	PB13	N/A

The UART header pinouts are designed to be used with FTDI USB-UART TTL (3.3V) converter cables (found at <http://www.ftdichip.com/Products/Cables/USBTTLSerial.htm>). One example is FTDI part TTL-232R-3V3.

6.7 Indicator LEDs

The development board includes six indicator LEDs.

Four LEDs (**LED1 – LED4**) are for development use and are connected to the MCU port of the EWB as indicated in [Table 3](#).

Table 3: EWB LEDs and signal mapping

Designator	Color	STM32F412 Port Name
LED1	Green	PB12
LED2	Red	PB15
LED3	Blue	PE7
LED4	Red	PE8

Note: The MCU connections to the LEDs can be removed by switching positions 1 – 4 of SW11 to the “OFF” position.

LED5 (Green) indicates when DC power is applied to the development board 3.3V regulator inputs.

LED6 (Green) indicates UART activity with the FTDI FT2232H USB UART/FIFO IC.

6.8 Push Buttons

SW2 and SW3 are SPST-NO tact switches that when pressed will provide a low logic level input to the MCU port of the EWB as indicated in [Table 4](#).

Table 4: EWB button signal mapping

Designator	STM32F412 Port Connection
SW2	PC13
SW3	PD1

Note: The EWB MCU connection to the buttons can be removed by switching positions 3(SW3) and 6(SW2) of SW10 to the OFF position.

6.9 MCU Wake Button

SW1 is SPST-NO tact switch connected to Port PA0 on the EWB STM32F412 MCU to provide the ability to use the WKUP function of the MCU to wake from Standby, Stop, and Sleep modes of operation.

6.10 BME680 Gas/Pressure/Temperature/Humidity Sensor

The development board includes the Bosch Sensortec BME680 air quality sensor connected to the EWB MCU I2C2 interface bus via pins PB10 (SCL) and PB11 (SDA). The I2C signal traces are pulled high on the development board.

6.11 External Host Interface

The EWB development board provides the capability to connect to an external host MCU that uses 1.8V - 5.0V logic levels.

The following peripherals and pin assignments of the EWB STM32F412 MCU are available on header J4 for connection to an external microcontroller host platform (Table 5).

Table 5: External host Interface connections

J4 Pin #	Name	Function	Type	EWB STM32F412 Port
1	GND	Ground	I	-
2	VCC_EXT_MCU	External Host I/O Voltage ^[1]	I	-
3	UART_CTS	CTS flow control (to external host)	O	UART3_RTS/PB14
4	UART_TX	TX Data (from external host)	I	UART3_RX/PC5
5	UART_RX	RX Data (to external host)	O	UART3_TX/PD8
6	UART_RTS	RTS flow control (from external host)	I	UART3_CTS/PB13
7	RESETn	EWB MCU reset	I	MICRO_RST_N
8	WKUPn	EWB MCU wake	I	MICRO_WKUP/PA0
9	BT_WAKE	Wake up Signal indicating EWB Bluetooth device requires attention	O	BT_HOST_WAKE
10	GPIO	General Purpose I/O	I/O	PE5
11	OEn	Level Shifter enable (active low) ^[2]	I	-
12	GND	Ground	I	-

Note: By default, EWB 3V3_MCU power is not provided to the level shifter interface IC on the development board.

^[1] Connect EWB module 3V3_MCU to the level shifter and set the logic level for the module interface lines by shorting solder bridge SB3 on the development board (Figure 7).

^[2] The OEn line is held low by default on the development board. J4 - pin 11 provides the option for the external host microcontroller to control this line. To allow this capability, the shorted solder bridge SB4 needs to be cut on the development board (Figure 7).

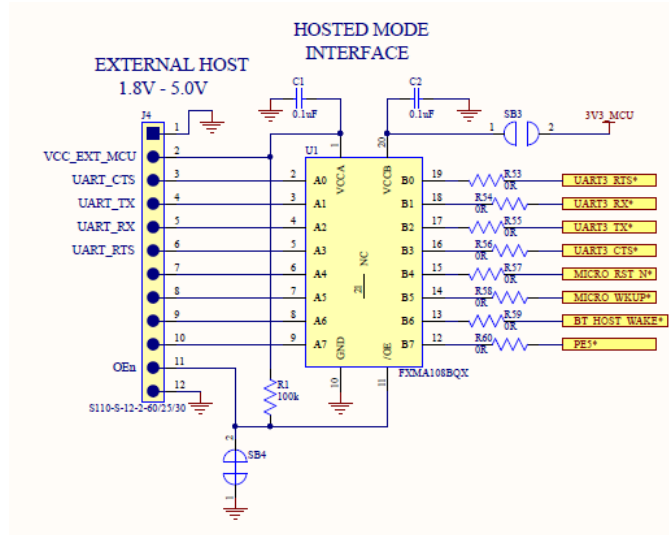

Figure 7: External HOST interface schematic and location of solder bridge modifications

7 BREAKOUT CONNECTOR PINOUTS

7.1 Trace debugging (JTAG) Interface

The development board provides access to the EWB module J-Link JTAG interface via connector **J10** (Figure 8).

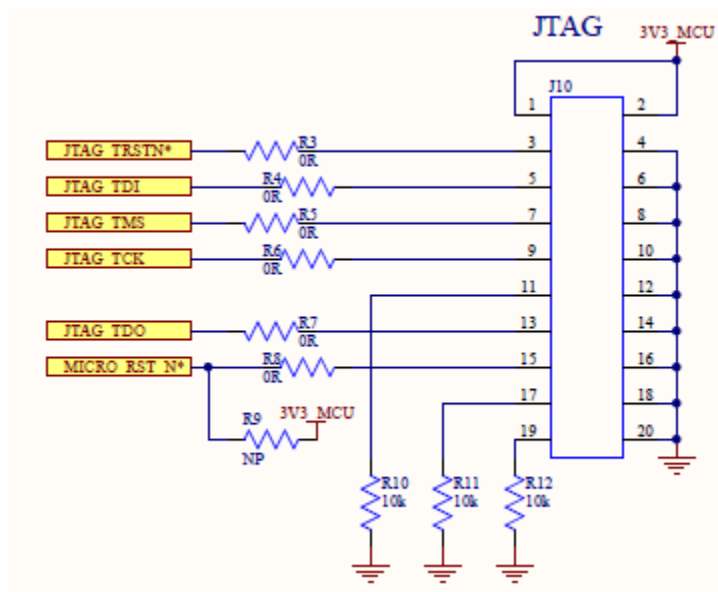

Figure 8: JTAG Interface schematic

7.2 Bluetooth Interface

Development board header **J3** provides access to the Bluetooth radio on the EWB module (Figure 9).

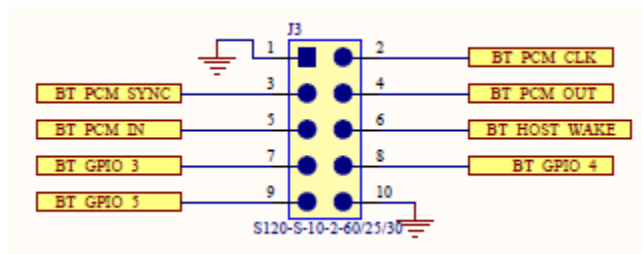

Figure 9: Bluetooth Interface PIN assignments

7.2.1 Bluetooth PCM Audio Interface

Four PCM audio connections are available.

- BT_PCM_CLK, BT_PCM_IN, BT_PCM_OUT, and BT_PCM_SYNC
- BT_PCM_CLK and BT_PCM_SYNC can be master (output) or slave (input).

7.2.2 Bluetooth GPIO Interface

Three Bluetooth General Purpose I/O lines are available for expansion capability.

7.2.3 Bluetooth Wake Interface

BT_HOST_WAKE output signal pin indicates when the EWB module Bluetooth radio requires attention.

7.3 PIN Breakout Headers

Access to the remaining EWB module signal pins is available on 0.1-inch pitch header connectors J5 and J6 (Figure 10 and Table 6).

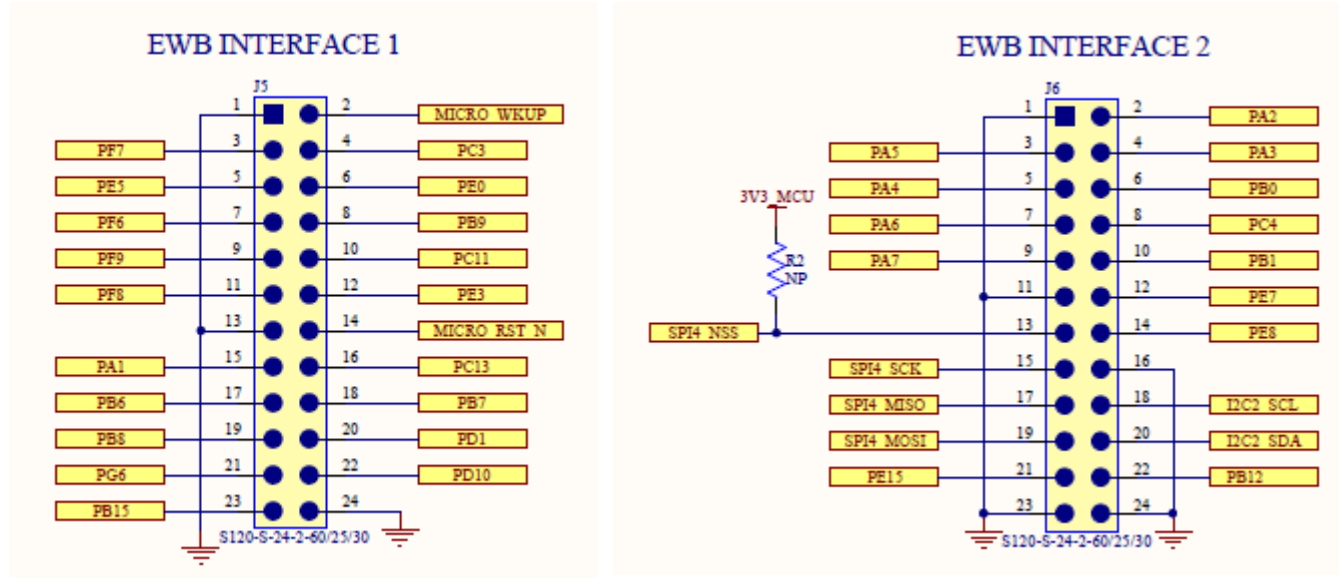

Figure 10: EWB breakout headers

Table 6: J5 and J6 pin mapping

Pin	Connection	Pin	Connection
1	GND	2	MICRO_WKUP/PA0
3	PF7	4	PC3
5	PE5	6	PE0
7	PF6	8	PB9
9	PF9	10	PC11
11	PF8	12	PE3
13	GND	14	MICRO_RST_N
15	PA1	16	PC13
17	PB6	18	PB7
19	PB8	20	PD1
21	PG6	22	PD10
23	PB15	24	GND

Pin	Connection	Pin	Connection
1	GND	2	PA2
3	PA5	4	PA3
5	PA4	6	PB0
7	PA6	8	PC4
9	PA7	10	PB1
11	GND	12	PE7
13	SPI4_NSS/PE11	14	PE8
15	SPI4_SCK/PE12	16	GND
17	SPI4_MISO/PE13	18	I2C2_SCL/PB10
19	SPI4_MOSI/PE14	20	I2C2_SDA/PB11
21	PE15	22	PB12
23	GND	24	GND

8 OTHER FEATURES

8.1 Current Consumption Measurements

The provided headers on the development board allow you to break the power supply lines and measure current consumption.

J1 (3V3_WIFI), J19 (3V3_MCU), and J15 (3V3_VDD) are available to connect an ammeter between the two pins. To enable a current measurement, the shorted solder bridge at each header will need to be cut first (Figure 11).

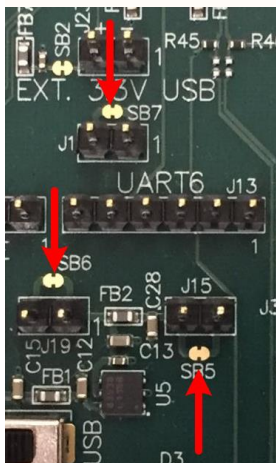
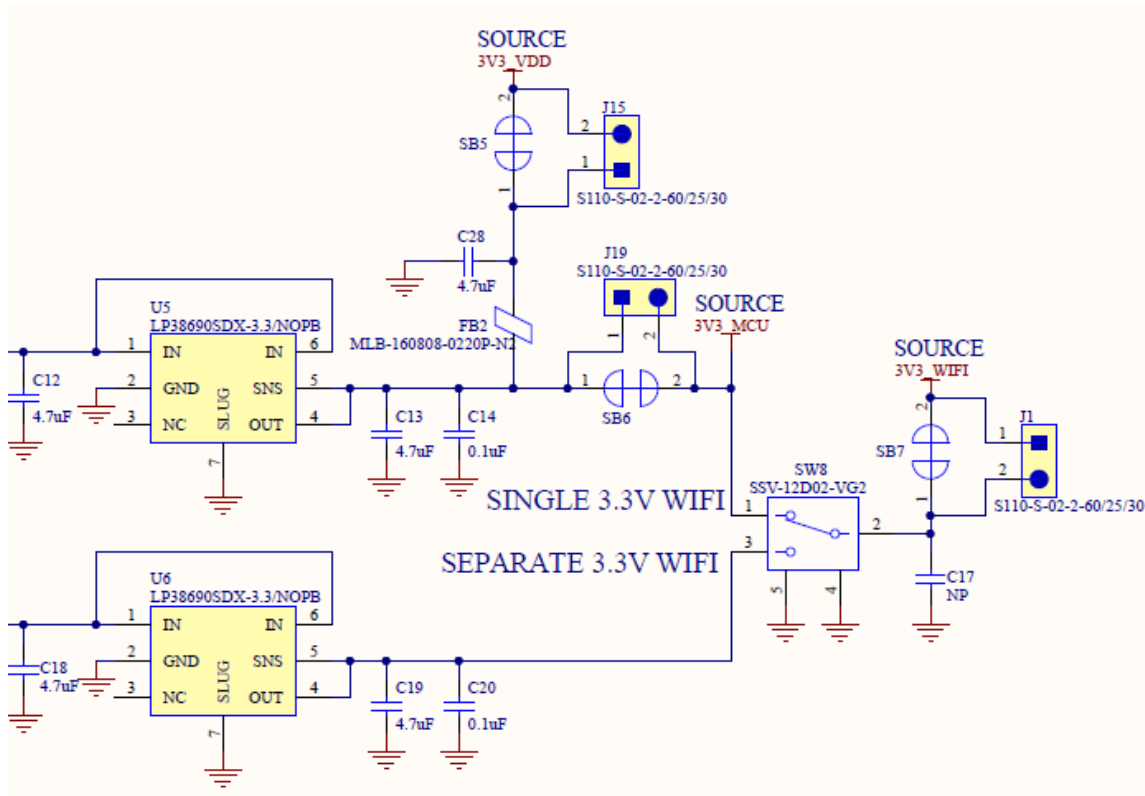

Figure 11: Current measurement schematic and PCB modifications

9 APPENDIX A – EWB MODULE PIN TO MCU PORT MAPPING

The mapping of the EWB module pinout to the STM32F412 MCU ports is provided in Table 7.

Table 7: EWB module to STM32 port mapping

Module Pin #	Name	STM32 Port
2	MICRO_ADC_IN2	PA2
3	MICRO_SPI1_SCK ^[1]	PA5
4	MICRO_SPI1_NSS ^[1]	PA4
5	MICRO_SPI1_MISO ^[1]	PA6
6	MICRO_ADC_IN3	PA3
7	MICRO_GPIO_5	PB0
8	QUADSPI_BK2_IO2	PC4
12	QUADSPI_BK2_IO3	PC5
13	MICRO_SPI1_MOSI ^[1]	PA7
14	BOOT1	PB2
15	QUADSPI_CLK	PB1
16	QUADSPI_BK2_IO0	PE7
17	MICRO_SPI4_NSS	PE11
18	QUADSPI_BK2_IO1	PE8
19	MICRO_SPI4_SCK	PE12
20	MICRO_I2C2_SCL	PB10
21	MICRO_SPI4_MISO	PE13
22	MICRO_I2C2_SDA	PB11
23	MICRO_SPI4_MOSI	PE14
24	MICRO_GPIO_16	PE15
26	MICRO_SPI2_NSS	PB12
27	MICRO_SPI2_SCK	PB13
28	MICRO_SPI2_MISO	PB14
30	MICRO_SPI2_MOSI	PB15
31	MICRO_GPIO27	PD8
32	MICRO_GPIO25	PD10
36	QUADSPI_BK1_NCS	PG6
38	MICRO_I2S2_CK	PC7
39	MICRO_I2S2_MCK	PC6
42	MICRO_USART1_RX	PA10
43	MICRO_USART1_TX	PA9
44	MICRO_GPIO_26	PD1
45	MICRO_GPIO_28	PB8
46	MICRO_I2C1_SDA	PB7
47	MICRO_USART1_CTS	PA11

Module Pin #	Name	STM32 Port
48	MICRO_I2C1_SCL	PB6
49	MICRO_USART1_RTS	PA12
50	MICRO_JTAG_TDI	PA15
51	MICRO_JTAG_TMS	PA13
53	BOOT0	BOOT0
54	MICRO_JTAG_TDO	PB3
55	PC13	PC13
56	MICRO_ADC_IN1	PA1
57	MICRO_JTAG_TCK	PA14
60	MICRO_RST_N	NRST
64	MICRO_JTAG_TRSTN	PB4
65	MICRO_GPIO_0	PE3
66	QUADSPI_BK1_IO0	PF8
67	QUADSPI_BK2_NCS	PC11
68	QUADSPI_BK1_IO1	PF9
69	MICRO_I2S2_WS	PB9
70	QUADSPI_BK1_IO3	PF6
71	MICRO_GPIO_30	PE0
72	OSC_32K_IN	PC14
73	MICRO_I2S_DI	PE5
74	OSC_32K_OUT	PC15
76	MICRO_WKUP	PA0
78	QUADSPI_BK1_IO2	PF7
79	MICRO_I2S2_SD	PC3

^[1]SPI1 is used for the internal EWB module 16 Mb flash communication (PA4, PA5, PA6, and PA7).

10 APPENDIX B – EWB/STM32F412 ALTERNATIVE FUNCTIONS

STM32 Port	USART			SPI						I2C			I2S			ADC
	1	3	6	1	2	3	4	5	QSPI	1	2	3	1	2	3	
BOOT0																
NRST																
PA0																0
PA1							MOSI		BK1_IO3							1
PA2														CKIN		2
PA3														MCK		3
PA4				NSS		NSS							WS		WS	4
PA5				SCK									CK			5
PA6				MISO					BK2_IO0				MCK			6
PA7				MOSI					BK2_IO1				SD			7
PA9	TX															
PA10	RX							MOSI								
PA11	CTS		TX				MISO									
PA12	RTS		RX					MISO								
PA13																
PA14																
PA15/ BOOT1	-			-						-		-				
PB0								SCK								8
PB1							NSS		CLK							9
PB2																
PB3	-			-						-		-				
PB4	-			-						-		-				
PB6	TX								BK1_NCS	SCL						
PB7	RX									SDA						
PB8								MOSI		SCL		SDA				
PB9					NSS					SDA	SDA			WS		
PB10		TX			SCK						SCL			CS	MCK	
PB11		RX									SDA			CKIN		
PB12		CK			NSS	SCK	NSS							WS		
PB13		CTS			SCK		SCK							CK		
PB14		RTS			MISO									eSD		
PB15					MOSI									SD		
PC3					MOSI									SD		13
PC4									BK2_IO2				MCK			14
PC5		RX							BK2_IO3							15
PC6			TX											MCK		
PC7			RX		SCK									CK	MCK	
PC11		RX				MISO			BK2_NCS						eSD	
PC13																

STM32 Port	USART			SPI						I2C			I2S			ADC
	1	3	6	1	2	3	4	5	QSPI	1	2	3	1	2	3	
PC14																
PC15																
PD1																
PD8		TX														
PD10		CK														
PE0																
PE3																
PE5							MISO	MISO								
PE7									BK2_IO0							
PE8									BK2_IO1							
PE11							NSS	NSS								
PE12							SCK	SCK								
PE13							MISO	MISO								
PE14							MOSI	MOSI								
PE15																
PF6									BK1_IO3							
PF7									BK1_IO2							
PF8									BK1_IO0							
PF9									BK1_IO1							
PG6									BK1_NCS							

Note: USART2 is used internally on the EWB module for MCU to radio communication and is not available.

SPI1 is used for the internal EWB module 16-Mb flash communication (PA4, PA5, PA6, and PA7).

11 ADDITIONAL DOCUMENTATION

Laird offers a variety of documentation and ancillary information to support our customers through the initial evaluation process and ultimately into mass production. Additional documentation can be accessed from the Sterling-EWB Product Page: <https://www.lairdconnect.com/wireless-modules/wi-fi-bt-modules/sterling-ewb-iot-module>

For any additional questions or queries, or to receive technical support for this Development Kit or for the Sterling-EWB module, please contact Embedded Wireless Solutions Support: <https://www.lairdconnect.com/resources/support>

© Copyright 2019 Laird. All Rights Reserved. Patent pending. Any information furnished by Laird and its agents is believed to be accurate and reliable. All specifications are subject to change without notice. Responsibility for the use and application of Laird materials or products rests with the end user since Laird and its agents cannot be aware of all potential uses. Laird makes no warranties as to non-infringement nor as to the fitness, merchantability, or sustainability of any Laird materials or products for any specific or general uses. Laird, Laird Technologies, Inc., or any of its affiliates or agents shall not be liable for incidental or consequential damages of any kind. All Laird products are sold pursuant to the Laird Terms and Conditions of Sale in effect from time to time, a copy of which will be furnished upon request. When used as a trademark herein, *Laird* means Laird PLC or one or more subsidiaries of Laird PLC. Laird™, Laird Technologies™, corresponding logos, and other marks are trademarks or registered trademarks of Laird. Other marks may be the property of third parties. Nothing herein provides a license under any Laird or any third-party intellectual property right.