

**COMFORT AND
OCCUPANCY MONITORING**



PRESENCE



SMART BUILDING



**SENLAB™ 0 IS THE DEVICE DESIGNED
FOR YOUR SMART BUILDING SOLUTION.**

Ref : PTL-LAB-41NS



6 years*
(replaceable battery)

15km* IP30
(Indoor use)

Local or Public
Network compliant

*Depending on the
operating conditions

Featuring the LoRaWAN™ connectivity protocol, this smart device embeds **4 functionalities "All in One" transmission : Temperature, relative humidity of the air, luminosity and presence.**

This Senlab offers best in class features such as :

- **Battery Life time up to 6 years**
- **Rich data content thanks to datalogging : Up to 12 measures / radio transmission**
- **Radio performances**
- **Advanced set of functionalities**
- **"Over the air" activation and reconfiguration**

TYPICAL APPLICATIONS

- Smart Building
- Monitor office comfort and presence
- Optimize Workspace optimization
- Compile occupancy rate
- Regulate energy costs
- Control and monitor energy consumption

TYPICAL SPECIFICATIONS

Physical specifications	Dimensions	50 x 91,5 x 25 mm
	Weight	65 gr
	Operating temperature	0°C to +55°C
RF specifications	RF sensitivity	-137dBm
	RF power	+14dBm (25mW)
	Radio band	868 MHz
EC Conformity : Compliant with Directive 2014/53/UE (RED)	EMC	Final draft EN 301 489-3 v2.1.1 Draft EN 301 489-1 v2.2.0
	Radio	EN 300 220-2 v3.1.1
	Magnetic field exposure	EN 62479
	Safety	EN 60950-1

DIMENSIONAL DRAWING

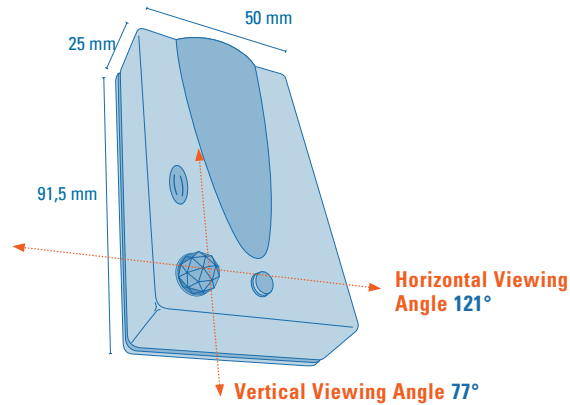

TECHNICAL FEATURES FOCUS

Plug & Play installation

- Double sided tape or screw mounting of door contacts (provided)
- Long term measure stability <math><0,02^\circ\text{C}/\text{Yr}</math> and <math><0,25\%\text{RH}/\text{Yr}</math> - no need for calibration
- Activation with magnet (LED feedback)

High configurability

- Temperature precision of $\pm 0.3^\circ\text{C}$ range [0 ; $+55^\circ\text{C}$]
- Humidity precision of $\pm 2\%\text{RH}$ range [$+10$; $+55^\circ\text{C}$] and [20%RH ; 80%RH]
- Luminosity range from a few lux up to 60k lux
- Light source type variations detection
- Presence detection range 3.5m minimum and wide detection angles (121°H / 77°V)
- Temperature High and Low threshold overrun configuration
- Log and transmit mode for battery lifetime enhancement (up to 12 compressed measures per transmission)
- Reconfiguration possible over the air

Network configuration

- LoRaWAN parameters (OTAA or ABP activation mode, initial datarate,...)
- Encryption keys customizable by client
- Standard LoRaWAN retries support
- Radio collisions avoidance by pseudo-randomization of transmissions
- Advanced transmission reliability mechanisms (recovery of lost messages, redundancy of data)

BATTERY LIFE DURATION ESTIMATION

This following matrix provides the estimated battery lifetime depending on the average spreading factor used by the Senlab and the transmission period.

	Tx period				
	15 min	30 min	1 h	2 h	3 h
SF7	5,5	5,6	5,7	5,8	5,8
SF8	5,2	5,5	5,7	5,7	5,8
SF9	4,8	5,2	5,5	5,6	5,7
SF10	4,1	4,8	5,2	5,4	5,5
SF11	3,2	4,1	4,7	5,1	5,3
SF12	2,3	3,2	4,1	4,6	4,8

Log period of 15 mn / 10 logs max per frame

For guidance and information purposes only.