

# Multi-turn Valve Sensor

## Product Manual

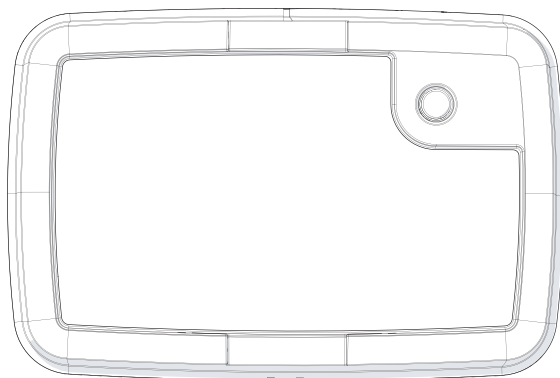

# Contents

<b>1</b>	<b>Product Introduction</b>	<b>4</b>
1.1	NEON Product Introduction . . . . .	4
1.2	Related Documents . . . . .	4
<b>2</b>	<b>Getting Started</b>	<b>5</b>
2.1	What you will need . . . . .	5
2.2	What is in the box . . . . .	5
<b>3</b>	<b>Product Specifications</b>	<b>6</b>
3.1	Product Nomenclature . . . . .	6
3.2	Product Dimensions . . . . .	7
3.3	Installation . . . . .	7
<b>4</b>	<b>Warnings</b>	<b>8</b>
<b>5</b>	<b>User Interface</b>	<b>9</b>
5.1	Operating the Device . . . . .	10
5.1.1	During calibration / resetting of the calibration . . . . .	10
5.1.2	When Operational . . . . .	10
<b>6</b>	<b>Calibration</b>	<b>11</b>
6.1	Calibrating the device . . . . .	11
6.2	Reset Calibration / Turning off the device . . . . .	12
6.3	Procedure . . . . .	12
<b>7</b>	<b>Troubleshooting</b>	<b>13</b>
7.1	Trouble shooting during calibration . . . . .	13
7.1.1	Time-out . . . . .	13
7.1.2	Blue LED . . . . .	13
7.1.3	Blinking Yellow LED . . . . .	13
7.1.4	Yellow LED . . . . .	13
7.2	Trouble shooting during normal operation . . . . .	13
7.2.1	Red LED . . . . .	13
7.2.2	Yellow LED . . . . .	13
<b>8</b>	<b>Product Functionalities</b>	<b>14</b>
8.1	Application Event Message . . . . .	14
8.1.1	Event-triggers . . . . .	14
8.1.2	Content application event message . . . . .	15
8.2	Device Status . . . . .	15
8.3	Default Configuration . . . . .	15
<b>9</b>	<b>Maintenance</b>	<b>16</b>
9.1	Battery Replacement . . . . .	16
9.1.1	Battery Specifications . . . . .	16
9.1.2	Required tools . . . . .	16
9.1.3	Disassembly of the device . . . . .	17
9.1.4	Assembly of the device . . . . .	17
<b>10</b>	<b>General Notes</b>	<b>18</b>
10.1	Do's and Don'ts . . . . .	18
10.2	Radio Specification . . . . .	18
10.3	Manufacturer information . . . . .	18



<b>11 Regulatory Information FCC</b>	<b>19</b>
11.1 RF exposure safety . . . . .	19
11.2 Class B device notice . . . . .	19

# 1 Product Introduction

## 1.1 NEON Product Introduction

NEON stands for a standardised approach to collecting data points from the operational environment and in doing so, creates a general approach to integrated solutions within existing IT ecosystems.

The TWTG NEON product range supports all industrial customers moving towards LoRaWAN as the Industrial IoT network of the future.

The LoRaWAN network gives industrial operations a secure solution, which scales-up to tens of thousands of sensors, covers complete sites with only a small amount of gateways and best of all – the low-power approach means that the lifetime of the NEON products can be extended dramatically.

## 1.2 Related Documents

Document Name	Document Number
NEON Data Sheet	607_P19-005 NEON Data Sheet VS MT
NEON Product Sheet	609_P19-005 NEON Product Sheet VS MT

**Table 1:** Related Documents

## 2 Getting Started

### 2.1 What you will need

In order to deploy the NEON Valve Sensor, a compatible and operational LoRa-WAN network architecture is required. This manual does not contain any instructions of how-to set-up and install LoRa-WAN networks.

TWTG offers radio network planning and IT architecture design services to fully integrate the products in the NEON product line.

### 2.2 What is in the box

When the product is delivered, check the components for damage and if all box items mentioned below are included.

Box Items	
NEON Valve Sensor	1 battery, included in the product
Magnet Key	1 per 20 devices
Product Sheet	incl. declaration of Conformity

**Table 2:** Box Items

### 3 Product Specifications

Product	
Product name	TWTG NEON multi-turn Valve Sensor
Type identification Transmitter	VS-868-01-MT01 / VS-915-01-MT02 / VS-923-01-MT03 / VS-923-01-MT04
Environmental conditions	
Ambient temperature range	-40 °C - 80 °C
Storage temperature range	10 °C - 30 °C
Water & dust resistance	IP65
Mechanical	
Material	Molded plastic
Dimensions	96x64x39 mm
Installation	
Sensor	Bracket Kit (not included)
Certifications	
ATEX 114 certificate number	DEKRA 18ATEX0106
IECEX 02 certificate number	IECEX DEK 18.0063
FCC ID	2ATYF-C19-001
FM ID US	FM20US0015X
FM ID CA	FM20CA0007X
Connectivity	
Protocol	LoRa-WAN
Frequency bands	See chapter 8.2 Radio Specification
Maximum RF output power	See chapter 8.2 Radio Specification

**Table 3:** Product specifications. See also "NEON datasheet" in [Related Documents](#) for a detailed overview of specifications.

Intended Region	
Europe	VS-868-01-MT01
US/Canada	VS-915-01-MT02
Singapore	VS-923-01-MT03
Malaysia	VS-923-01-MT04

**Table 4:** Intended Region

#### 3.1 Product Nomenclature

Modelname		Serial number	
aa	Product type	tt	Product type
fff	Operating frequency	fff	Operating frequency
cc	Major revision number	yy	Year of manufacture
xx	Software functionality	xxxxxx	Individual identifier
yy	Indication of regional variant Serial number		

**Figure 1:** LoRa multi-turn Valve Sensor product Nomenclature

### 3.2 Product Dimensions

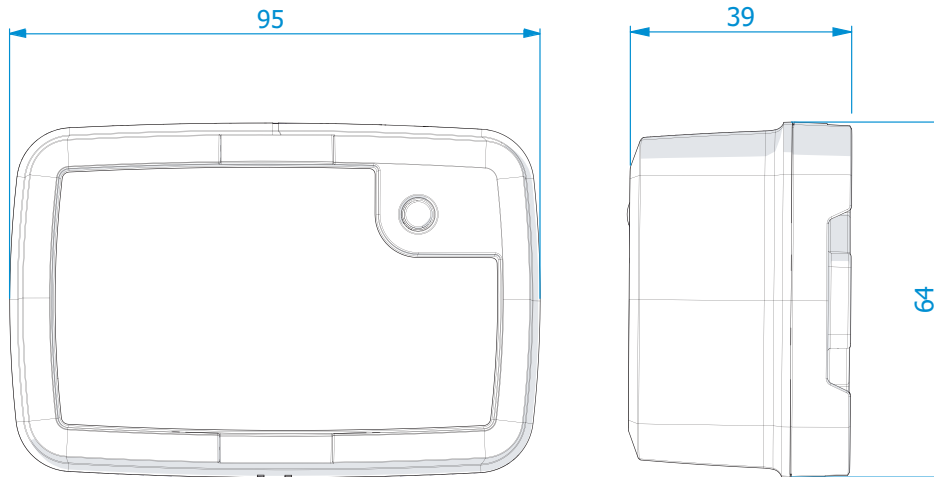

Figure 2: NEON Valve Sensor Dimensions (mm)

### 3.3 Installation

- 1: Installation needs to be performed according to IEC 60079-14;
- 2: Installation shall only be carried out by trained and authorised personnel;
- 3: Installation only as instructed in this product installation manual.

The sensor must be calibrated in its final installed position. Keep metal objects and/or magnetic fields away from the sensor during and after calibration.

When the sensor is moved or has been displaced a re-calibration is required.

The device works with LoRa WAN connectivity, a LoRa WAN network must be present for the sensor to operate.

For installation instructions please refer to the installation manual at [www.twtg.io/products/neon-valve-sensor-mt](http://www.twtg.io/products/neon-valve-sensor-mt).

## 4 Warnings



### English

- 
- **WARNING - DO NOT OPEN WHEN AN EXPLOSIVE ATMOSPHERE IS PRESENT**
  - **WARNING - POTENTIAL ELECTROSTATIC CHARGING HAZARD - SEE INSTRUCTIONS**
  
  - DO NOT OPEN DEVICE There are no user serviceable parts within;
  - The device enclosure shall be cleaned only by the use of a water-damped cloth. The use of dry cloths and / or chemical agents shall be prohibited;
  - If damage to the enclosure is noticed, the discoverer shall immediately inform a competent and trained person, who shall remove the device from service as soon as possible, and return to the manufacturer;
  - This equipment is only intended for use in restricted access areas;
  - If the device doesn't function as documented, remove the product from the IECex / ATEX environment and dispose accordingly by returning it to the manufacturer;
  - If a device is no longer connecting with gateways, it shall be returned to the manufacturer for examination;
  - If a device is in contact with chemical materials please clean it appropriately.
- 



### French

- 
- **AVERTISSEMENT - NE PAS OUVRIR EN PRESENCE D'UNE ATMOSPHERE EXPLOSIVE**
  - **AVERTISSEMENT - DANGER POTENTIEL DE CHARGE ELECTROSTATIQUE – VOIR INSTRUCTIONS**
  
  - NE PAS OUVRIR LE PRODUIT Aucune pièce interne ne peut être réparée par l'utilisateur;
  - Le boîtier ne doit être nettoyé seulement à l'eau, à l'aide d'un chiffon humide. Ne pas utiliser de chiffon sec ou/et quelconque produits chimiques;
  - Si le boîtier est endommagé, merci d'informer immédiatement un personnel qualifié afin de retirer le produit et de le retourner au fabricant;
  - Le produit est dédié à une utilisation dans une zone sécurisée par un contrôle d'accès;
  - En cas de dysfonctionnement fonctionnel du produit, le retire de toute zone explosive (ATEX/IECex) et le retourner au fabricant.;
  - Dans l'éventualité où le produit ne communique pas/plus avec les routeurs installés sur site, le produit doit être retourner au fabricant pour de plus amples investigations;
  - Dans l'éventualité où le produit entre en contact avec un produit chimique, le nettoyer en suivant les consignes ci-dessus.
-

## 5 User Interface

The device has one LED in the upper right corner to provide feedback to the user. To interact with the device a magnet switch is present inside the product. To use this switch the user must be in possession of a magnet key, which should be placed as instructed below. The magnet key can be held in position for different actions in the process.

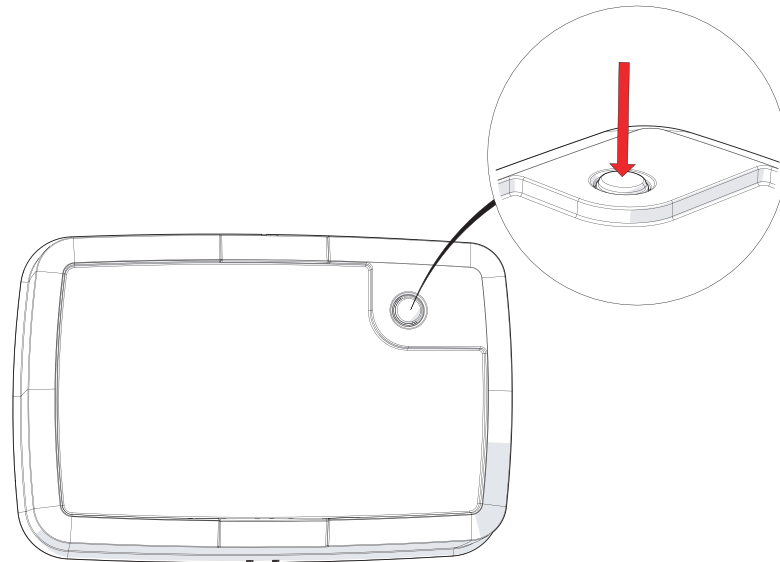

**Figure 3:** LED indicator on the device

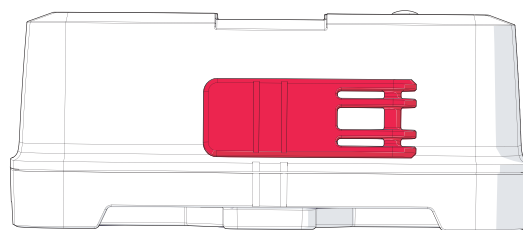

**Figure 4:** Placement of magnet key

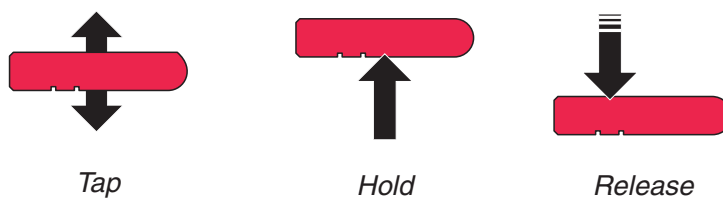

**Figure 5:** Magnet key icon definitions

## 5.1 Operating the Device

### 5.1.1 During calibration / resetting of the calibration

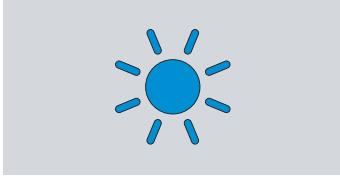

**Blue (Steady):** user action required

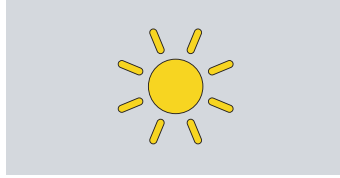

**Yellow (Steady):** measuring / wait...

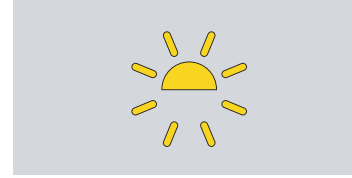

**Yellow (Blinking):** connecting / wait...

### 5.1.2 When Operational

When the valve is turned to the open position and is kept in this position for at least 6 seconds. The device senses no further movement and determines that the valve has been opened. The LED will show blue / red / blue / red, and then turns off.

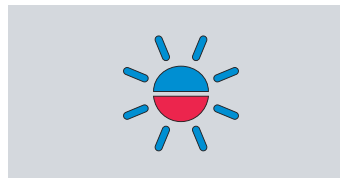

**Blue/Red (Blinking):** Open

When the valve is turned to the closed position and is kept in that position for at least 6 seconds. The device senses no further movement and determines that the valve has been shut. The LED will show blue / green / blue / green, and then turns off.

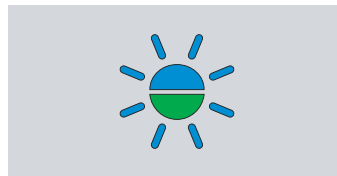

**Blue/Green (Blinking):** Shut

Tap the magnet key to request the device state.

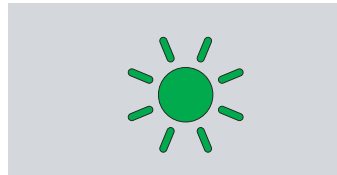

**Green (Steady):** Application ready / Calibrated

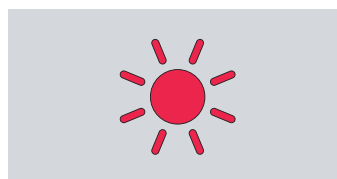

**Red (Steady):** Application not ready / Uncalibrated

## 6 Calibration

### 6.1 Calibrating the device

#### Step 1 -SHUT the valve-

**Step 2 -Hold magnet key-** on the indicators of the device and after 2 seconds the device will show its state;

- Red (Steady): **-Hold magnet key-** Device is uncalibrated, proceed.
- Green (Steady): **-Release magnet key-** Device is calibrated. No further steps are required OR follow the procedure for resetting the calibration (page 11).

#### Step 3 -Release magnet key-

Yellow (Blinking)  
Connecting/wait...(max. 2 min);

- Yellow (Steady): Measuring/wait...(max. 2min).
- Blue (Steady): User action required...(max. 30sec).

**Step 4 -OPEN the valve-** by turning the wheel more than 180 degrees;

**Step 5 -Tap magnet key-** to tell the device that the valve is opened;

- Yellow (Steady): Measuring/wait...(max. 2min).
- Blue (Steady): User action required...(max. 30sec).
  - Red (Steady): Time-out...(go back to step 1).

#### Step 6 -SHUT the valve-

**Step 7 -Tap magnet key-** to tell the device that the valve is shut;

- Yellow (Steady): Measuring/wait...(max. 2min).
- Yellow (Blinking): Connecting/wait...(max. 2min).
- Green (Steady): Calibrated.
  - Red (Steady): Time-out...(go back to step 1).

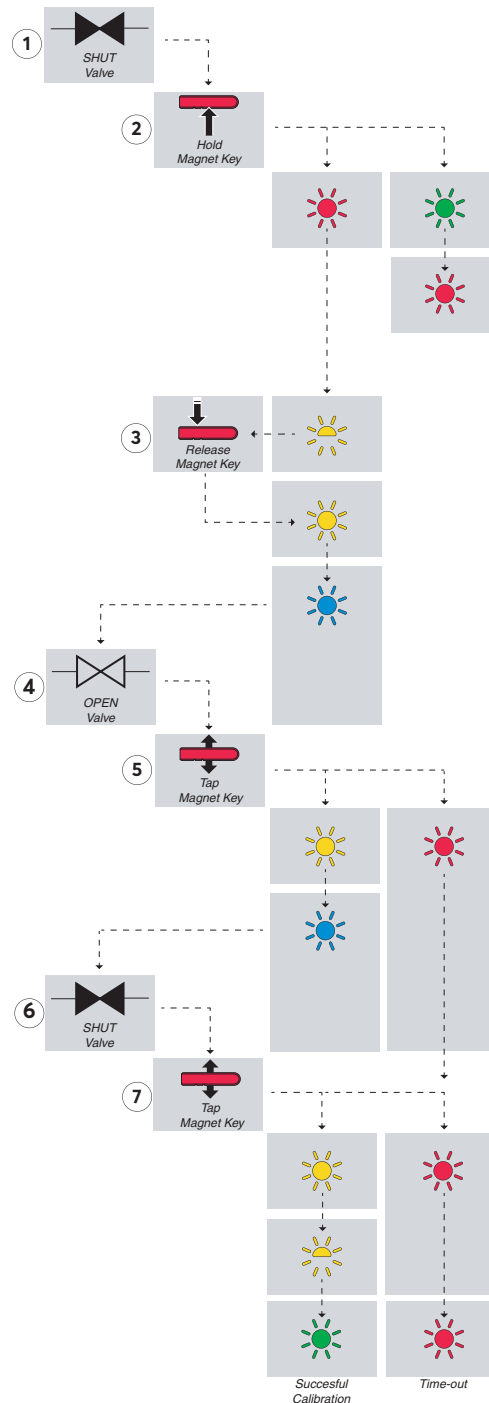

## 6.2 Reset Calibration / Turning off the device

In some cases it might be necessary to reset the calibration of the device:

- 1: When the device is being reinstalled, relocated or removed;
- 2: When the network has changed;
- 3: When the device does not function as expected.

## 6.3 Procedure

### Step 1 -SHUT the valve-

**Step 2 -Hold magnet key-** on the indicators of the device, after 2 seconds the device will show its state;

- Red (Steady): **-Release magnet key-** Device is uncalibrated, no further steps required.
- Green (Steady): **-Hold magnet key-** Device is calibrated, keep holding the magnet key for 4 more seconds.
  - Red (Steady): **-Release magnet key-** Device is uncalibrated, no further steps required.

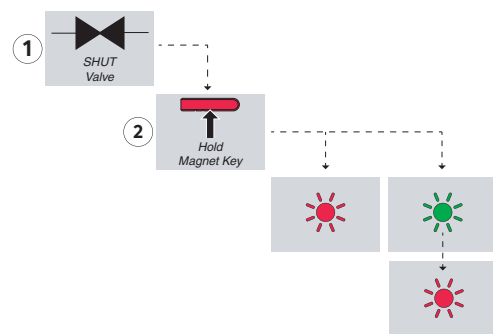

## 7 Troubleshooting

When the device is being calibrated or when the device is operational, in exceptional cases certain steps in the process might not succeed.

When the device is successfully connected to the network and problems occur, the troubleshooting should be performed on the network side. The device is working correctly.

### 7.1 Trouble shooting during calibration

#### 7.1.1 Time-out

Time-out is a time limit for the completion of a certain process step. This can occur in three states:

- When a user action is required (steady blue LED);
- When the device is connecting to the network (blinking yellow LED);
- When the device is processing (steady yellow LED).

#### 7.1.2 Blue LED

The blue LED will stay on for a maximum of 30 seconds;

- If the required user action is not completed within 30 seconds → time-out (steady red LED) → the device resets the calibration.

#### 7.1.3 Blinking Yellow LED

A blinking yellow LED will stay active for a maximum of 2 minutes;

- If connecting to the network failed → time-out (steady red LED) → the device resets the calibration.

#### 7.1.4 Yellow LED

The yellow LED will stay on for a maximum of 30 seconds;

- If the sensor reading during calibration is not stable → time-out (steady red LED) → the device resets the calibration.

### 7.2 Trouble shooting during normal operation

#### 7.2.1 Red LED

The red LED will stay on for a maximum of 5 seconds during normal operations;

- The sensor turns off and will reboot after 1 hour into normal operations.

#### 7.2.2 Yellow LED

The yellow LED will stay on for a maximum of 30 seconds;

- If the sensor reading during calibration is not stable → time-out (steady red LED) → the device resets the calibration.

## 8 Product Functionalities

A detailed description of setting-up communication and configuring device settings can be found in "Communication protocol", refer to table 1. [Related Documents](#).

### 8.1 Application Event Message

The application event message contains information on the valve state. It is either triggered by a state transition, change in open levels or periodic (scheduled).

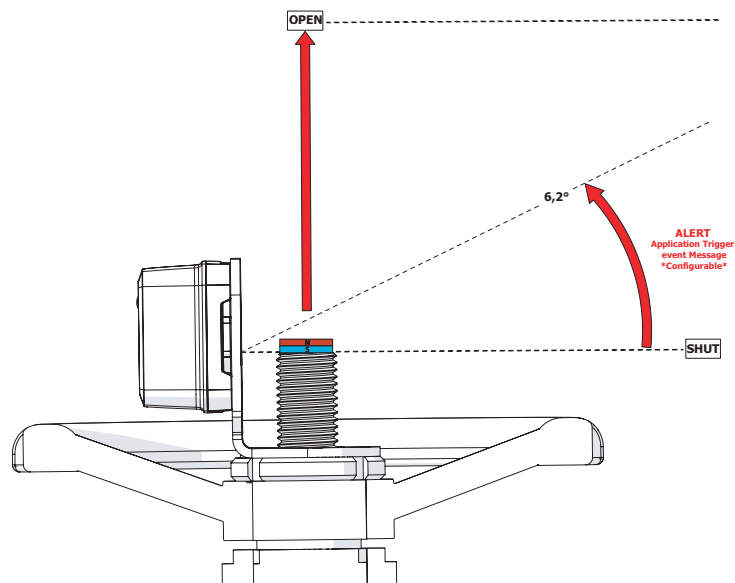

Figure 6: Application trigger event message

#### 8.1.1 Event-triggers

Event-messages are triggered on one of the following triggers.

- **State change:**

State change of the valve (Open or Shut)

- *Threshold of application trigger (Open or Shut) event message is configurable.*

- **Timer (periodic):**

The timer trigger is configurable through the following configurations:

- *magnet\_measurement\_interval\_seconds*

Interval in seconds, at which the NEON Valve Sensor is read.

- *Periodic\_event\_message\_interval\_seconds*

Interval in seconds at which the application event messages are periodically sent. The periodic counter is reset on every event message.

### 8.1.2 Content application event message

- **Trigger**

Source of the trigger for the application event message:

- "timer" (0);
- "condition\_0" (1);
- "condition\_1" (2);
- "condition\_2" (3);
- "condition\_3" (4).

- **Condition\_n**

The current state of each condition.

## 8.2 Device Status

Besides reporting on the valve state as discussed previously, the NEON Valve Sensor also reports on the device status itself. This is done through a device status messages. A device status message is sent periodically and includes a range of device health parameters, including the following:

- event\_counter;
- battery\_voltage;
- PCB temperature;
- tx\_counter;
- avg\_rssi;
- avg\_snr.

See "Communication Protocol" in [Related Documents](#) for a detailed explanation.

## 8.3 Default Configuration

The Neon Valve Sensor is delivered with a default configuration. The default configuration includes:

- Measurement interval of 2 seconds;
- Device status message interval of 24 hours;
- Enabled confirmation message on all messages.

See "Communication Protocol" in [Related Documents](#) for a detailed explanation of all default configuration values.

## 9 Maintenance

### 9.1 Battery Replacement

The battery can be replaced using the battery replacement kit. This kit consists of the following parts:

- 1X SAFT LS-17500 battery
- 1X Gasket

#### 9.1.1 Battery Specifications

Specifications	
Manufacturer	Saft
Part number	LS-17500
Quantity	1
Battery Type / Size	Type A
Chemistry	Lithium Thionyl Chloride
Terminal Type	Standard
Dimensions	50.9 x 17.13 mm
Battery Life	>3-5 years*

**Table 5:** Battery Specifications

*\*Note: Applicable for default configuration. Battery lifetime depends on average ambient temperature, network quality and device configuration.*



**WARNING - Only use the battery as specified in table 5. [Battery Specifications](#)**

#### 9.1.2 Required tools

- Torque screwdriver with TX20 bit;
  - See 9.1.4 Assembly of the device for torque settings;
- Loctite 243;
- ESD strap.



**IMPORTANT: ESD Sensitive Electronics**

The product shall be installed in such a way that the risk for electrostatic discharges is minimised.

- Take proper precaution such as a grounded wrist strap and avoid touching the electronics board.

### 9.1.3 Disassembly of the device

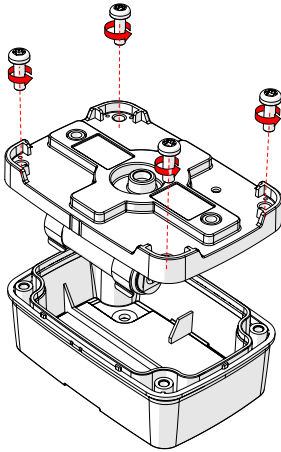

**Step 1:** Remove the four screws and remove the lower housing

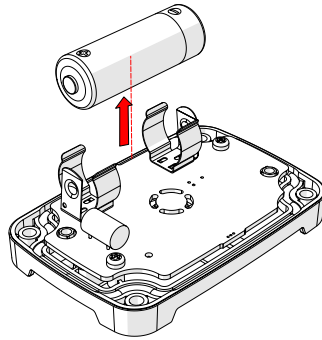

**Step 2:** Remove the battery

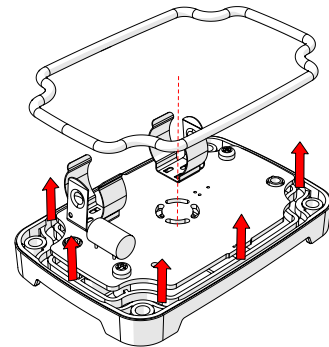

**Step 3:** Remove the gasket from the outer edge of the enclosure

### 9.1.4 Assembly of the device

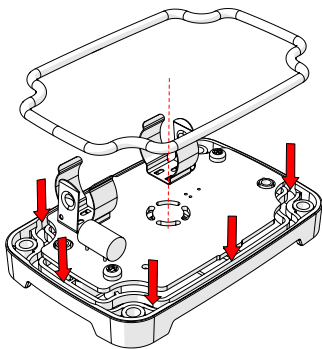

**Step 4:** Place the new gasket in the outer edge of the enclosure

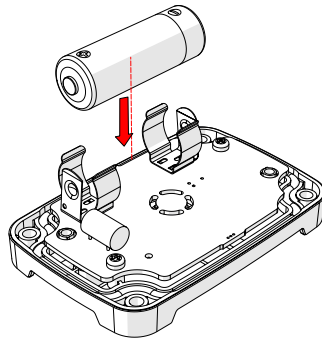

**Step 5:** Place the new battery

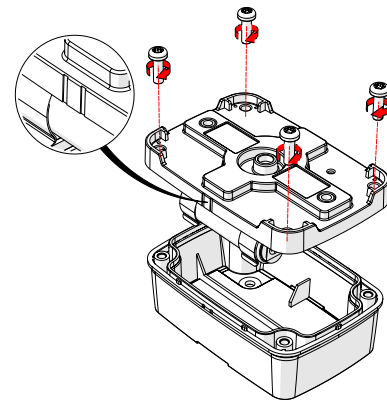

**Step 6:** Place the lower housing back on the upper housing. Please make sure that the two cutout lines in the lower housing match the upper housing. Tighten the four screws to fix the lower housing (max. 1Nm)

## 10 General Notes

### 10.1 Do's and Don'ts

- 1: Don't leave a magnet key near the device during or after installation;
- 2: Don't leave anything on the device after installation;
- 3: If the label is damaged, return the device for refurbishment;
- 4: If product or mounting parts are damaged, return the device for refurbishment.

### 10.2 Radio Specification

This product contains a LoRa radio modem operating at 868 MHz, 915 MHz and 923 MHz see tabel below. This product requires access to a LoRa gateway in order to function as described.

	Frequency range	Maximum power
LoRaWAN 868 MHz	868.0 - 868.6 MHz	13.8 dBm / 0.024 W
LoRaWAN 915 MHz	902.3 - 903.7 MHz	12.9 dBm / 0.0196 W
LoRaWAN 923 MHz	920.0 - 925.0 MHz	13.6 dBm / 0.0557 W

**Table 6:** Radio specification

Hereby, TWTG R&D B.V. declares that the radio equipment type "LoRa modem" is in compliance with Directive 2014/53/EU. The full text of the EU declaration of conformity is available at the following internet address: [www.twtg.io/legal](http://www.twtg.io/legal)

### 10.3 Manufacturer information

TWTG R&D B.V.  
 Schoordijk 386  
 2909 LA Capelle a/d IJssel  
 The Netherlands  
[www.twtg.io](http://www.twtg.io)

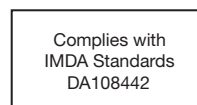

## 11 Regulatory Information FCC

Changes or modifications not expressly approved by the party responsible for compliance could void the user's authority to operate the equipment.

This device complies with part 15 of the FCC Rules. Operation is subject to the following two conditions: (1) This device may not cause harmful interference, and (2) this device must accept any interference received, including interference that may cause undesired operation.

### 11.1 RF exposure safety

This device complies with the FCC RF exposure limits and has been evaluated in compliance with mobile exposure conditions.

The equipment must be installed and operated with minimum distance of 20 cm of the human body.

### 11.2 Class B device notice

NOTE: This equipment has been tested and found to comply with the obligations for a Class B digital device, pursuant to part 15 of the FCC Rules. These limits are designed to provide reasonable protection against harmful interference in a residential installation. This equipment generates, uses, and can radiate radio frequency energy and, if not installed and used in accordance with the instructions, may cause harmful interference to radio communications. However, there is no guarantee that interference will not occur in a particular installation. If this equipment does cause harmful interference to radio or television reception, which can be determined by turning the equipment off and on, the user is encouraged to try to correct the interference by one or more of the following measures:

- Reorient or relocate the receiving antenna;
- Increase the separation between the equipment and receiver;
- Connect the equipment into an outlet on a circuit, different from that to which the receiver is connected;
- Consult the dealer or an experienced radio/TV technician for help.